



Approved Pricing Methodology

1 July 2015 to 30 June 2018

February 2015

Version 2.2

Security Classification: Public



ElectraNet Corporate Headquarters

52-55 East Terrace, Adelaide, South Australia 5000 • PO Box, 7096, Hutt Street Post Office, Adelaide, South Australia 5000
Tel: (08) 8404 7966 • Fax: (08) 8404 7104 • Toll Free: 1800 243 853

ElectraNet Pty Ltd (ElectraNet) is the principal electricity *Transmission Network Service Provider* (TNSP) in South Australia.

At ElectraNet we:

- Recognise that a strong and reliable electricity *transmission system* is important to the economy and future security of supply
- Consult with stakeholders and take their views into consideration
- Respond appropriately to our customers' needs
- Provide efficient electricity *transmission services*

Meet the challenge to keep costs down when key drivers are pushing costs up

For information about ElectraNet visit www.electranet.com.au.

Contact

For enquiries about this proposed *pricing methodology* please contact:

Bill Jackson
Pricing Manager
ElectraNet
52-55 East Terrace
Adelaide SA 5000

Copyright and Disclaimer

Copyright in this material is owned by or licensed to ElectraNet. Permission to publish, modify, commercialise or alter this material must be sought directly from ElectraNet.

Reasonable endeavours have been used to ensure that the information contained in this report is accurate at the time of writing. However ElectraNet gives no warranty and accepts no liability for any loss or damage incurred in reliance on this information.

Revision Record					
Date	Version	Description	Author	Checked By	Approved By
May 07	1.0	Initial Version			
May 12	2.0	Amended Version	Bill Jackson Pricing Manager	Simon Appleby Senior Manager Regulatory Affairs	Rainer Korte Executive Manager Network Strategy & Regulatory Affairs
2 Feb 15	2.1	Amended for IR Charging for informal review	Bill Jackson Pricing Manager	Simon Appleby Senior Manager Regulation and Land Development	Rainer Korte Executive Manager Asset Management
19 Feb 15	2.2	Amended for IR Charging	Bill Jackson Pricing Manager	Simon Appleby Senior Manager Regulation and Land Development	Rainer Korte Executive Manager Asset Management
3 Mar 15	2.2	Removal of draft and watermarks	Bill Jackson Pricing Manager	Simon Appleby Senior Manager Regulation and Land Development	Simon Appleby Senior Manager Regulation and Land Development

Contents

1.	INTRODUCTION.....	1
2.	INTERPRETATION.....	1
3.	PRESCRIBED TRANSMISSION SERVICES.....	1
4.	RULES REQUIREMENTS.....	2
5.	PRICING METHODOLOGY GUIDELINES REQUIREMENTS.....	3
6.	PROPOSED PRICING METHODOLOGY.....	4
6.1	BACKGROUND.....	4
6.2	COORDINATING NETWORK SERVICE PROVIDER.....	5
6.3	AGGREGATE ANNUAL REVENUE REQUIREMENT.....	6
6.4	CATEGORIES OF TRANSMISSION SERVICES.....	6
6.5	THE PRICING PROCESS.....	7
6.6	COST ALLOCATION.....	7
6.7	CALCULATION OF THE ATTRIBUTABLE COST SHARE FOR EACH CATEGORY OF SERVICE.....	8
6.8	CALCULATION OF THE ANNUAL SERVICE REVENUE REQUIREMENT (ASRR).....	9
6.9	ALLOCATION OF THE ASRR TO TRANSMISSION NETWORK CONNECTION POINTS.....	10
6.10	MODIFIED COST REFLECTIVE NETWORK PRICING METHODOLOGY.....	14
6.11	TRANSMISSION PRICES AND CHARGES.....	16
6.12	STANDBY SERVICE ARRANGEMENTS.....	19
6.13	EXCESS DEMAND CHARGE.....	20
6.14	SETTING OF PRESCRIBED TUOS SERVICES LOCATIONAL PRICES BETWEEN ANNUAL PRICE PUBLICATIONS.....	20
7.	BILLING ARRANGEMENTS.....	21
7.1	BILLING FOR PRESCRIBED TRANSMISSION SERVICES.....	21
7.2	PAYMENTS BETWEEN TRANSMISSION NETWORK SERVICE PROVIDERS.....	21
8.	PRUDENTIAL REQUIREMENTS.....	21
8.1	PRUDENTIAL REQUIREMENTS FOR PRESCRIBED TRANSMISSION SERVICES.....	21
8.2	CAPITAL CONTRIBUTION OR PREPAYMENT FOR A SPECIFIC ASSET.....	22
9.	PRUDENT DISCOUNTS.....	22
10.	MONITORING AND COMPLIANCE.....	22
11.	DIFFERENCES BETWEEN CURRENT AND PROPOSED PRICING METHODOLOGIES.....	23

12.	ADDITIONAL INFORMATION REQUIREMENTS.....	23
13.	CONCLUSION	23
APPENDIX A	STRUCTURE OF TRANSMISSION PRICING UNDER PART J OF RULES 24	
APPENDIX B	DETAILS OF COST ALLOCATION PROCESS.....	25
APPENDIX C	COST REFLECTIVE NETWORK PRICING METHODOLOGY.....	27
APPENDIX D	RATINGS ADJUSTMENT FOR CALCULATING UTILISATION FACTORS	29
APPENDIX E	PRIORITY ORDERING METHODOLOGY	30
APPENDIX F	INTER-REGIONAL TRANSMISSION CHARGING	42
1.	INTRODUCTION.....	42
2.	OVERVIEW OF THE PROCESS	42
3.	TIMETABLE FOR THE PROVISION OF DATA.....	45
4.	BILLING THE MODIFIED LOAD EXPORT CHARGE.....	45
5.	BILLING ARRANGEMENTS BETWEEN MULTIPLE TNSPS IN A REGION.....	46
5.1	ALLOCATION OF AMOUNTS TO EACH TNSPS IN THE SAME REGION	46
5.2	BILLING EACH TNSP IN THE SAME REGION	46
6.	WORKED EXAMPLE – MODIFIED LOAD EXPORT CHARGE	46

Tables

Table 1:	Hypothetical costs allocated to <i>categories of prescribed transmission services</i>	9
Table 2:	Hypothetical <i>attributable cost shares</i>	9
Table 3:	Hypothetical Annual Service Revenue Requirements	10
Table 4:	Hypothetical <i>prescribed entry services</i> ORCs	10
Table 5:	Hypothetical <i>attributable connection point cost shares</i>	11
Table 6:	Hypothetical <i>connection point ASRRs</i> (entry).....	11
Table 7:	Hypothetical <i>Connection point ASRRs</i> (exit)	12

1. Introduction

ElectraNet Pty Ltd (ElectraNet) is the principal electricity *Transmission Network Service Provider* (TNSP) in South Australia.

On 28 February 2013 the Australian Energy Markets Commission (AEMC) made the National Electricity Amendment (Inter-regional Transmission Charging) Rule 2013. This Rule sets out the arrangement for the calculation and charging of inter-regional transmission charges between adjacent *regions* and the recovery and/or dispersal of these charges from and/or to customers in each region.

In order to give effect to this Rule amendments are required to be made to the pricing methodology guidelines in accordance with clause 11.64.2 of the Rules and the approved pricing methodology in accordance with clause 11.64.3 of the Rules.

These amendments are limited to those required to calculate, charge and recover the modified load export charges (*MLEC*) both between regions and within *regions* as required by the Rule change.

This *proposed amended pricing methodology* for the period from 1 July 2015 to 30 June 2018¹, is submitted to the Australian Energy Regulator (AER) in accordance with the requirements of Chapter 6A of the National Electricity Rules (the Rules) and the AER's amended *pricing methodology guidelines*.

2. Interpretation

All terms in this proposed *pricing methodology* that are italicised have the meaning given to them in Chapter 10 of the Rules. All other terms which are defined in the *pricing methodology guidelines* or, where no definition is provided in that document, in the Rules will have the same meaning when used in this proposed *pricing methodology*.

A reference to the Rules is taken to be a reference to the current version of the National Electricity Rules, version 49, which commenced operation on 5 April 2012 as that version of the Rules is amended from time to time.

A reference to the old Rules is taken to be a reference to version 9 of the National Electricity Rules which was operative between 27 July 2006 and 15 November 2006.

3. Prescribed Transmission Services

ElectraNet's proposed *pricing methodology* relates to the provision of *prescribed transmission services* in the South Australian region by ElectraNet and Murraylink and any other *Transmission Network Service Provider* who provides *prescribed transmission services* within the South Australian *region*. These services include:

¹ Subject to clauses 6A.24.3 and 6A.24.4 of the Rules which set down the basis for setting prices pending approval of *the pricing methodology* and pending the approval of *maximum allowed revenue* respectively.

- *Shared transmission services* provided to customers directly connected to the *transmission network* and connected *Network Service Providers* (*prescribed TUOS services*);
- *Connection services* provided to connect the *ETSA Utilities distribution network* to the *transmission network* (*prescribed exit services*);
- Grandfathered *connection services* provided to *Generators* and customers directly connected to the *transmission network* for *connections* that were in place or committed to be in place on 9 February 2006 (*prescribed entry services* and *prescribed exit services*); and
- Services required under the Rules or in accordance with *jurisdictional electricity legislation* that are necessary to ensure the integrity of the *transmission network*, including the maintenance of power system security and assisting in the planning of the power system (*prescribed common transmission services*).

For the avoidance of doubt the proposed *pricing methodology* does not relate to the provision of *negotiated transmission services* or other *transmission services* provided by ElectraNet (*non-regulated transmission services*) that are not subject to economic regulation under Chapter 6A of the Rules.

4. Rules Requirements

Clause 6A.24.1(b) of the Rules states that a *pricing methodology* is a methodology, formula, process or approach that, when applied by a TNSP (or a *Co-ordinating Network Service Provider* on behalf of TNSPs within a *region*):

1. allocates the *aggregate annual revenue requirement* for *prescribed transmission services* provided by the TNSP to each *category of prescribed transmission services*;
2. provides for the manner and sequence of adjustments to the *annual service revenue requirement*;
3. allocates the *annual service revenue requirement* to *transmission network connection points* (other than *connection points* of any *Market Network Service Provider*); and
4. determines the structure and recovery of prices for each *category of prescribed transmission services* under 6A.23.4(a).

Clause 6A.24.1(b1) of the Rules further states that in addition to complying with any other requirements under Chapter 6A, the *pricing methodology* of a *Transmission Network Service Provider* that is the *Co-ordinating Network Service Provider* for a *region* must provide for:

1. the allocation of the *AARR* for *prescribed transmission services* provided by *Transmission Network Service Providers* within that *region*, including any allocation of the *AARR* as agreed between *Transmission Network Service Providers* in accordance with clause 6A.29.3;
2. the calculation of *modified load export charges* consistent with clause 6A.29A.2;
3. the allocation and billing of *modified load export charges*:
 - (i) receivable by other *Co-ordinating Network Service Providers* in *interconnected regions*; and

- (ii) payable to other *Co-ordinating Network Service Providers* in *interconnected regions*;
- to each *Transmission Network Service Provider* within its *region* under clause 6A.29A.5; and
4. the allocation of proceeds from *auctions* or a portion of *settlements residue* receivable by or payable to the *Transmission Network Service Provider* in its *region* as referred to in clause 6A.23.3(b)(1).

The Rules also require that the *pricing methodology* satisfy principles and guidelines established by the Rules. In particular, clause 6A.10.1(e)² of the Rules requires that a proposed *pricing methodology* must:

1. give effect to and be consistent with the *Pricing Principles for Prescribed Transmission Services* (i.e. the principles set out in Rule 6A.23 of the Rules); and
2. comply with the requirements of, and contain or be accompanied by such information as is required by, the *pricing methodology guidelines* made for that purpose under Rule 6A.25 of the Rules.

Further, under clause 6A.24.1(d)³ of the Rules a TNSP must comply with:

- the *pricing methodology* approved by the AER as part of a *transmission determination* that applies to that TNSP, and
- any other applicable requirements in the Rules,

when the TNSP is setting the prices that may be charged for the provision of *prescribed transmission services*.

5. Pricing Methodology Guidelines Requirements

The *pricing methodology guidelines* supplement and elaborate on the *Pricing Principles for Prescribed Transmission Services* contained in Chapter 6A of the Rules in so far as they specify or clarify:

- the information that is to accompany a proposed *pricing methodology*;
- permitted pricing structures for the recovery of the locational component of *prescribed TUOS services*;
- permitted postage-stamp pricing structures for the recovery of the adjusted non-locational component of *prescribed TUOS services* and *prescribed common transmission services*;
- the types of *transmission system* assets that are directly attributable to each *category of prescribed transmission services*; and
- the parts of a proposed *pricing methodology*, or the information accompanying it that will not be publicly disclosed without the consent of the TNSP.

² Also clause 6A.24.1(c)

³ The formatting of the actual words used in clause 6A.24.1(d) of the Rules has been changed (by separating out the 2 dot points) in order to emphasise the fact that ElectraNet must comply with both its *pricing methodology* and the other applicable requirements of the Rules.

All key elements of ElectraNet's *proposed pricing methodology* are permissible under the *pricing methodology guidelines*. These elements include:

- calculation of the locational component of *prescribed TUOS services* costs using the *modified cost reflective network pricing methodology*;
- the locational *prescribed TUOS services* price being based on contract agreed maximum demand and
- the postage-stamp basis of pricing structures for the non-locational component of *prescribed TUOS services* and *prescribed common transmission services* being based on contract agreed maximum demand or historical energy;
- the methodology for implementation of priority ordering (being the priority ordering approach under clause 6A.23.2(d) of the Rules);
- a description of how asset costs which may be attributable to both *prescribed entry services* and *prescribed exit services* will be allocated at a *connection point*;
- a description of billing arrangements under clause 6A.27 of the Rules;
- a description of prudential requirements as outlined in clause 6A.28 of the Rules;
- the inclusion of hypothetical worked examples;
- a description of any differences between the *pricing methodology* applied during the current *regulatory control period* and that proposed for the next *regulatory control period*; and
- a description of how ElectraNet intends to monitor and develop records of its compliance with its approved *pricing methodology*, the *Pricing Principles for Prescribed Transmission Services* (clause 6A.23 of the Rules) and part J of the Rules in general.

6. Proposed Pricing Methodology

6.1 Background

ElectraNet's first published transmission pricing methodology, applicable from 1 January 2003 to 30 June 2008, was developed in accordance with Part C of Chapter 6 of the old Rules and was approved by the ACCC. This methodology featured the use of the *modified cost reflective network pricing methodology* provided for under the old Rules and currently permissible under clause 6A.23.3(a) of the Rules.

ElectraNet's *pricing methodology*, applicable from 1 July 2008 to 30 June 2013, was prepared to satisfy the requirements of the *Pricing Principles for Prescribed Transmission Services*, Part J of the Rules and the AER's *pricing methodology guidelines*. It again featured the use of the *modified cost reflective network pricing methodology* and was approved by the AER in its decision of April 2008.

The approved proposed *pricing methodology*, applicable from 1 July 2013 to 30 June 2015, proposed minor amendments to:

- reflect the changes to the Rules that have occurred subsequent to the approval of the current pricing methodology, specifically the Rule change of January 2010 which varied the provisions of clause 11.6.11 of the Rules; and

- modifications to the standby provisions of section 6.12 of this proposed *pricing methodology* to encourage customers to better manage their peak demand and reduce their impact on the transmission *network* at times of high network utilisation.

This *proposed amended pricing methodology* applicable from 1 July 2015 to 30 June 2018, proposes minor amendments to:

- give effect to the National Electricity Amendment (Inter-regional Transmission Charging) Rule 2013 and
- reflect the requirements of the *amended pricing methodology guidelines*.

6.2 Coordinating Network Service Provider

In accordance with clause 6A.29.1 of the Rules, ElectraNet is the *Co-ordinating Network Service Provider* for the South Australian *region* and collects both ElectraNet's and the Murraylink Transmission Company (MTC)'s regulated revenue entitlements via ElectraNet's *prescribed transmission service prices*.

These prices incorporate the full impact of the *MLEC* and no payments or liabilities arise between ElectraNet and MTC under clause 6A.29A.5(a) of the Rules⁴.

As the *Co-ordinating Network Service Provider* ElectraNet is responsible for:

1. the allocation of all relevant *AARR* within the *region*, including any allocation of the *AARR* as agreed between *Transmission Network Service Providers* in accordance with clause 6A.29.3 of the Rules;
2. the calculation of *modified load export charges* and any adjustments to the charges in accordance with the *Rules* payable by *Co-ordinating Network Service Providers* in *interconnected regions*; and
3. the allocation and billing of *modified load export charges* and any adjustments to the charges in accordance with the *Rules* payable or receivable to or from *Co-ordinating Network Service Providers* in *interconnected regions* to each *Transmission Network Service Provider* within its *region*.

MTC is required to advise ElectraNet annually of the *Aggregate Annual Revenue Requirement (AARR)* for its *transmission system* assets which are used to provide *prescribed transmission services* within the South Australian *region*. It is also required to provide any other information reasonably required by ElectraNet to ensure the proper calculation of *prescribed transmission service prices* in South Australia⁵.

Additional requirements with respect to the provision of information for the calculation of the *MLEC* are specified in Appendix F.

⁴ Notwithstanding this bills will be issued to satisfy the requirements of clause 6A.29A.5(b) of the Rules.

⁵ This obligation will also apply to any additional appointing providers requiring the services of the co-ordinating network service provider during the life of this pricing methodology.

6.3 Aggregate Annual Revenue Requirement

The revenue that a TNSP may earn in any *regulatory year* of a *regulatory control period* from the provision of *prescribed transmission services* is known as the *maximum allowed revenue*⁶.

The *AARR* is calculated in accordance with clause 6A.22.1 of the Rules as:

“the *maximum allowed revenue* referred to in clause 6A.3.1 adjusted:

1. in accordance with clause 6A.3.2,
2. by subtracting the operating and maintenance costs expected to be incurred in the provision of *prescribed common transmission services*; and
3. by any allocation as agreed between *Transmission Network Service Providers* in accordance with clause 6A.29.3.”

The adjustments referred in (1) above could relate to a number of factors including:

- reopening of the *revenue determination* for capital expenditure (not being a *pass through event* or a *contingent project*) under clause 6A.7.1 of the Rules;
- *network support pass through* under clause 6A.7.2 of the Rules;
- cost pass through under clause 6A.7.3 of the Rules;
- *service target performance incentive scheme* outcomes under clause 6A.7.4 of the Rules;
- *contingent projects* under Rule 6A.8 of the Rules; or
- revocation of *revenue determination* for wrong information or error under clause 6A.15 of the Rules.

The costs referred in (2) above are derived from budget projections and include:

- *network* switching and operations;
- administration and management of the business;
- *network* planning and development; and
- general overheads.

6.4 Categories of transmission services

ElectraNet’s and MTC’s *AARRs* are recovered from transmission charges for the following *categories of prescribed transmission services*:

- *Prescribed entry services* which include services provided by assets that are directly attributable to serving a *Generator* or group of *Generators* at a single *connection point* and are deemed to provide a *prescribed transmission service* by virtue of the operation of clause 11.6.11 of the Rules;
- *Prescribed exit services*, which include services provided by assets that are directly attributable to serving a *Transmission Customer* or group of *Transmission Customers* at a single *connection point* and: (a) are deemed

⁶ Clause 6A.3.1 of the Rules.

prescribed by virtue of the operation of clause 11.6.11 of the Rules; or (b) are *exit services* provided to *Distribution Network Service Providers*;

- *Prescribed common transmission services*, which are services that provide equivalent benefits to all *Transmission Customers* without any differentiation based on their location, and therefore cannot be reasonably allocated on a locational basis; and
- *Prescribed transmission use of system (TUOS) services*, which include services that provide benefits to *Transmission Customers* depending on their location within the *transmission system*, that are shared to a greater or lesser extent by all users across the *transmission system* and are not *prescribed common transmission services*, *prescribed entry services* or *prescribed exit services*.

6.5 The pricing process

The determination of *prescribed transmission service* prices involves four steps:

1. Allocation of the costs of *transmission system* assets to the *categories of prescribed transmission service*, to the extent to which assets are directly attributable to the provision of a *category of prescribed transmission services* (Section 6.6);
2. Calculation of the *attributable cost shares* (Section 6.7);
3. Calculation of the *Annual Service Revenue Requirement (ASRR)* by the allocation of the *AARR* to each *category of prescribed transmission services* in accordance with the *attributable cost share* for that *category of prescribed transmission services* (Section 0); and
4. Allocation of the *annual service revenue requirement (ASRR)* for *prescribed entry services*, *prescribed exit services* and *prescribed TUOS services* to each *transmission network connection point* in accordance with the principles set out in clause 6A.23.3 of the Rules (Section 0).

Each step is described in further detail below.

6.6 Cost allocation

The **first step** in calculating *prescribed transmission service* prices is to allocate the costs of *transmission system* assets to the *categories of prescribed transmission services* in section 6.4 above, to the extent to which assets are directly attributable to the provision of a *category of prescribed transmission services*.

The delineation between the assets that provide *prescribed entry services*, *prescribed exit services*, *prescribed TUOS services* and *prescribed common transmission services* is set out in clause 2.4 of the *pricing methodology guidelines*.

The ElectraNet cost allocation process assigns the optimised replacement cost (ORC)⁷ of all *prescribed transmission services* assets to either *prescribed common transmission services* (assets that benefit all *Transmission Customers*) or individual *network pricing branches* (*transmission lines* and *transformers*). Each *network pricing branch* is then defined as entry, exit or shared network. The pricing branches are used

⁷ Consistent with clause 6A.22.3(b) of the Rules.

to determine the costs of the *transmission system* assets directly attributable to each *category of prescribed transmission services*, as required under Chapter 6A of the Rules. This cost allocation process is explained in more detail in Appendix B.

6.6.1 Assets attributable to prescribed entry services and prescribed exit services

In the case of a shared *connection asset* (such as a *transformer*) serving multiple *transmission connection points*, which may provide both *prescribed entry services* and *prescribed exit services*, the cost of the shared *connection asset* will be allocated to the appropriate category or categories of *prescribed transmission services* using an appropriate causal cost allocator⁸. For example:

- *generation or reactive plant* nameplate rating capacity or agreed maximum demand (AMD) supplied by the specified category of *prescribed transmission services* as a percentage of the total capacity and demand of all categories of *prescribed transmission services* at that location: Costs are attributable based on the capacity and/or AMD agreed upon by the customer(s);
- unit of plant method: Costs are allocated based on the number of units of plant installed (typically circuit breakers) where these units of plant can be attributed to a particular *category of prescribed transmission service*; or
- as negotiated between the connecting parties.

This process would also be adopted to allocate shared costs to individual *connection points*.

6.7 Calculation of the attributable cost share for each category of service

The **second step** in calculating *prescribed transmission service* prices is the calculation of the *attributable cost shares*. The *attributable cost share* for each *category of prescribed transmission services* is calculated in accordance with clause 6A.22.3 of the Rules as the ratio of:

1. The costs of the *transmission system* assets directly attributable to the provision of that *category of prescribed transmission services*; to
2. The total costs of all the TNSP's *transmission system* assets directly attributable to the provision of *prescribed transmission services*,

where these amounts are determined as detailed in section 6.6 above.

For example, if the ORC's of *prescribed transmission services* assets have been allocated to the applicable *categories of prescribed transmission services* as shown in Table 1 then the *attributable costs shares* are calculated as shown in the hypothetical example below:

$$\begin{aligned} \text{Attributable cost share}_{\text{EXIT}} &= \text{ORC}_{\text{EXIT}} / \text{ORC}_{\text{TOTAL}} \\ &= \$4,083,333 / \$43,050,000 \\ &= 0.0.095 \end{aligned}$$

with the *attributable cost shares* of the other categories of *prescribed transmission services* calculated in the same manner, as shown in Table 2.

⁸ This is consistent with ElectraNet's *cost allocation methodology* which is used to allocate costs between *prescribed transmission services*, *negotiated transmission services* and *non-regulated transmission services*.

Table 1: Hypothetical costs allocated to *categories of prescribed transmission services*

Category	ORC
<i>Exit service</i>	4,083,333
<i>Entry service</i>	716,667
<i>TUOS service</i>	37,500,000
<i>Common Service</i>	750,000
Total	43,050,000

Table 2: Hypothetical *attributable cost shares*

Category	ORC	Attributable cost share
<i>Exit service</i>	4,083,333	0.095
<i>Entry service</i>	716,667	0.017
<i>TUOS service</i>	37,500,000	0.871
<i>Common Service</i>	750,000	0.017
Total	43,050,000	1.000

6.8 Calculation of the Annual Service Revenue Requirement (ASRR)

The **third step** in calculating *prescribed transmission service* prices is to allocate the AARR to each *category of prescribed transmission services* in accordance with the *attributable cost share* for that *category of prescribed transmission services*.

This allocation results in the ASRR for each *category of prescribed transmission services*.

Assuming an AARR of \$2,504,434 and applying the *attributable cost shares* determined above, the ASRR for each *category of prescribed transmission services* is calculated as:

$$\begin{aligned}
 ASRR_{EXIT} &= AARR \times \text{Attributable cost share}_{EXIT} \\
 &= \$2,504,434 \times 0.095 \\
 &= \$237,548
 \end{aligned}$$

with the ASRRs of the other categories of *prescribed transmission services* calculated in the same manner.

Table 3: Hypothetical Annual Service Revenue Requirements

Category	Attributable cost share	Annual Service Revenue Requirement (ASRR)
<i>Exit service</i>	0.095	237,548
<i>Entry service</i>	0.017	41,692
<i>TUOS service</i>	0.871	2,181,563
<i>Common Service</i>	0.017	43,631
Total	1.000	2,504,434

6.9 Allocation of the ASRR to transmission network connection points

The **fourth step** in calculating *prescribed transmission service* prices is to allocate the ASRR for *prescribed entry services*, *prescribed exit services* and *prescribed TUOS services* to each *transmission network connection point* in accordance with the principles of clause 6A.23.3 of the Rules.

6.9.1 Prescribed entry services

The whole of the ASRR for *prescribed entry services* is allocated to each *transmission network connection point* in accordance with the *attributable connection point cost share* for *prescribed entry services* that are provided by the TNSP at that *connection point*.

The *attributable connection point cost share* for *prescribed entry services* is the ratio of the costs of the *transmission system* assets directly attributable to the provision of *prescribed entry services* at that *transmission network connection point* to the total costs of all the TNSP's *transmission system* assets directly attributable to the provision of *prescribed entry services*.

For example, if two *Generators*, Gen A1 and Gen A2, receive *prescribed entry services* and the cost allocation process has allocated the ORCs of assets *directly attributable* to *prescribed entry services* to them as shown in Table 4.

$$\begin{aligned}
 \text{Attributable connection point cost share}_{\text{GEN A1}} &= \text{ORC}_{\text{GEN A1}} / \text{ORC}_{\text{ENTRY}} \\
 &= \$250,000 / \$716,667 \\
 &= 0.349
 \end{aligned}$$

with the *attributable connection point cost share* of the other *Generator* being calculated in the same manner as shown in Table 5.

Table 4: Hypothetical *prescribed entry services* ORCs

Entry	ORC
Gen A1	250,000
Gen A2	466,667
Total ORC of prescribed entry assets	716,667

Table 5: Hypothetical *attributable connection point cost shares*

Entry	ORC	<i>Attributable connection point cost share</i>
Gen A1	250,000	0.349
Gen A2	466,667	0.651
Total	716,667	1.000

The *ASRR* allocated to the Gen A1 *transmission network connection point* is calculated as follows:

$$\begin{aligned}
 ASRR_{\text{GEN A1}} &= ASRR_{\text{ENTRY}} \times \text{Attributable connection point cost share}_{\text{GEN A1}} \\
 &= \$41,692 \times 0.349 \\
 &= \$14,544
 \end{aligned}$$

with the *ASRR* for the Gen A2 *transmission network connection point* being calculated in the same manner.

Table 6: Hypothetical *connection point ASRRs (entry)*

Entry	ORC	<i>Attributable connection point cost share</i>	<i>Connection point ASRR</i>
Gen A1	250,000	0.349	14,544
Gen A2	466,667	0.651	27,148
Total	716,667	1.000	41,692

6.9.2 Prescribed exit services

The whole of the *ASRR* for *prescribed exit services* is allocated to each *transmission network connection point* in accordance with the *attributable connection point cost share* for *prescribed exit services* that are provided by the TNSP at that *connection point*.

The *attributable connection point cost share* for *prescribed exit services* is the ratio of the costs of the *transmission system* assets directly attributable to the provision of *prescribed exit services* at that *transmission network connection point* to the total costs of all the *transmission system* assets directly attributable to the provision of *prescribed exit services*.

The *ASRRs* of the *prescribed exit services connection points* are calculated in the same manner as for the *prescribed entry services connection points*.

Table 7: Hypothetical *Connection point ASRRs* (exit)

Exit	ORC	Attributable <i>connection point</i> cost share	<i>Connection point</i> ASRR
Load A1	1,050,000	0.257	61,084
Load A2	883,333	0.216	51,388
Load B1	1,550,000	0.380	90,171
Load C1	600,000	0.147	34,905
Total	4,083,333	1.000	237,548

6.9.3 Prescribed Transmission Use of System (TUOS) services

The *prescribed TUOS (shared network) services ASRR* is recovered from:

- *Prescribed TUOS services* (locational component); and
- *Prescribed TUOS services* (the adjusted non-locational component).

Clause 6A.23.3(a) of the Rules requires that:

“The *annual service revenue requirement* for *prescribed TUOS services* is to be allocated between a locational component (*pre-adjusted locational component*) and a non-locational component (*pre-adjusted non-locational component*) either:

1. as to 50% to each component; or
2. an alternative allocation to each component, that is based on a reasonable estimate of future *network* utilisation and the likely need for future *transmission* investment, and that has the objective of providing more efficient locational signals to *Market Participants, Intending Participants* and end users.”

Consistent with clause 6A.23.3(b)-(d) of the Rules, the locational share of the *prescribed TUOS services ASRR* is adjusted by:

- subtracting estimated *inter-regional settlements residue auction* proceeds or any portion of *settlements residue* allocated to the *directional interconnector* which is not subject to a *settlement residue distribution (SRD)* agreement (This adjustment is calculated in accordance with 6A.23.3(f)⁹ of the Rules). The estimated proceeds are converted to an equivalent asset replacement cost, which is offset against the asset replacement cost of the relevant *interconnector* network assets. If the equivalent asset replacement cost is greater than the *interconnector* asset costs, then the *interconnector* asset costs are set to zero and the outstanding portion of the estimated proceeds is offset against the non-

⁹ The difference between budget estimates and actual amounts in the settlement residue auction proceeds (Clause 6A.23.3(b)(1)), the modified load export charge (MLEC) (Clause 6A.23.3(b)(2)), and the under and over recovery amounts (Clause 6A.23.3(e)(5)) are to be adjusted in accordance Clause 6A.23.3(f) of the Rules.

locational TUoS component. The reduced network costs are used as an input to the *modified cost reflective network pricing methodology (modified CRNP methodology)*¹⁰;

- adding or subtracting the estimated *modified load export charge* determined in accordance with clause 6A.29A of the Rules. This adjustment is calculated in accordance with 6A.23.3(f)² of the Rules; and
- If the adjusted locational component is a positive amount, then it is to be allocated to *connection points of transmission customers* using the *modified CRNP methodology* in accordance with clause 6A.23.3(c) of the Rules. If the adjusted locational component is a negative amount, then the adjusted locational amount is deemed to be zero and the non-locational component adjusted to recover this amount in accordance with clause 6A.23.3(d) of the Rules.

The adjusted share of the *ASRR* is allocated between *connection points* on the basis of the estimated proportionate use of the relevant *transmission system* assets by each customer using the *modified CRNP methodology*.

The *CRNP methodology* allocates a proportion of shared *network* costs to individual customer *connection points*. ElectraNet applies the *CRNP methodology* using the TPRICE *cost reflective network pricing* software approved by the AER for use by *TNSPs* in the *NEM*.

The *CRNP methodology* requires three sets of input data:

- an electrical (loadflow) model of the *network*;
- a cost model of the *network* (the results of the cost allocation process described in Appendix B); and
- an appropriate set of *load/generation* patterns.

Appendix C describes the *CRNP methodology* in more detail.

The remainder of the *ASRR* (the pre-adjusted non-locational component) is to be adjusted in accordance with clause 6A.23.3(e) of the Rules by:

- subtracting the absolute value of any negative adjusted locational component (referred to above);
- by subtracting or adding any remaining *settlements residue* (not being *settlements residue* referred to in the determination of the locational component but including the portion of *settlements residue* due to *intra-regional loss factors*) which is expected to be distributed or recovered (as the case may be) to or from the *TNSP* in accordance with clause 3.6.5(a) of the Rules;
- for any *over-recovery amount* or *under-recovery amount* from previous years including an adjustment in accordance with 6A.23.3(f),¹¹

¹⁰ In this way estimated *settlements residue* auction proceeds recover a portion of the *AARR* allocated to shared *network* costs on a locational basis.

¹¹ The difference between budget estimates and actual amounts in the settlement residue auction proceeds (Clause 6A.23.3(b)(1)), the modified load export charge (MLEC) (Clause 6A.23.3(b)(2)), and the under and over recovery amounts (Clause 6A.23.3(e)(5)) are to be adjusted in accordance Clause 6A.23.3(f) of the Rules.

- for any shortfall or over-recovery that arises from limiting the change in locational prices at a *connection point* (Clauses 6A.23.4(c) & (d) of the Rules); and
- for any amount arising as a result of the application of prudent discounts.

6.10 Modified Cost Reflective Network Pricing Methodology

The essential difference between standard *CRNP methodology* and *modified CRNP methodology* is that in calculating the network costs to be recovered on a locational basis (i.e. *prescribed TUOS services* – locational component):

- The standard *CRNP methodology* allocates shared *network costs* to *connection points* on the basis of optimised replacement costs and assumes a 50-50 split between the locational and non-locational components of *network charges*;
- The *modified CRNP methodology* uses utilisation adjusted replacement costs. An average rate of return¹² is applied to the resulting costs allocated to each *connection point* to determine its share of the locational component of shared *network charges* (i.e. the arbitrary 50 - 50 split used with the standard *CRNP methodology* is removed). *Prescribed TUOS services* – non-locational charges recover the balance of *network costs* (the costs not recovered by *prescribed TUOS services* – locational charges).

The *modified CRNP methodology* is intended to encourage better utilisation of existing assets by discounting the costs allocated to under-utilised elements relative to those that are more heavily utilised.

TPRICE calculates utilisation factors based on the maximum loading of each *network pricing branch* over the range of operating conditions analysed and pricing branch ratings provided as input to TPRICE.

In determining the utilisation factors required by Schedule 6A.3.3(2) of the Rules the *modified CRNP methodology* ensures that asset utilisation is based on the maximum flow allowed on *network elements* within the normal operating constraints of the *network* to prevent inefficient discounting of costs in the meshed *network*.

As TPRICE performs its calculations based on system normal operating conditions (i.e. with all elements in service) and does not carry out contingency analysis that is representative of the normal operating constraints of the *network*, it is necessary to apply an adjustment factor reducing branch ratings for input to TPRICE to ensure that utilisation factors appropriately take into account *network contingencies*.

Appendix D describes the ratings adjustment for calculation of utilisation factors in more detail.

6.10.1 Load and generation data

As noted in Appendix C, the choice of operating conditions is important in developing prices using the *CRNP methodology*. ElectraNet has flexibility in the choice of operating conditions, but notes that the old Rules set out the principles that should

¹² The rate of return is calculated so that *prescribed TUOS services* – locational charges would recover the full cost of the shared *network* when all *network elements* are assumed to be 100% utilised.

apply in determining the sample of operating conditions considered. Of particular note is the requirement that operating conditions to be used are to include at least 10 days with high system *demand*, to ensure that loading conditions, which impose peak flows on all *transmission elements*, are captured.

Schedule 6A.3.2(3) of the Rules is less prescriptive requiring that the allocation of *dispatched generation to loads* be over a range of actual operating conditions from the previous *financial year* and that the range of operating scenarios be chosen so as to include the conditions that result in most stress on the *transmission network* and for which *network* investment may be contemplated.

Clause 2.2(a) of the *pricing methodology guidelines* requires that prices for the recovery of the locational component of *prescribed TUOS services* are based on demand at times of greatest utilisation of the *transmission network* and for which *network* investment is most likely to be contemplated in accordance with clause 6A.23.4(e) of the Rules.

The use made of the *network* by particular *loads* and *generators* will vary considerably depending on the *load* and *generation* conditions on the *network*. For this reason a number of operating scenarios are examined with different *load* and *generation* patterns.

In selecting those operating scenarios it is important to recognise that the operating conditions that impose most stress on particular *network elements* may occur at times other than for system peak demand.

The TPRICE capacity method of cost allocation (used by ElectraNet) automatically captures the peak loading conditions on *network elements* from the sample of operating conditions analysed.

ElectraNet, therefore, uses the full year of operating data (i.e. 365 days of half hourly data) to avoid the need for judgement concerning an appropriate set of operating conditions.

Consistent with clause 2.2(f) of the *pricing methodology guidelines* where actual operating conditions from the previous complete *financial year* are unavailable for a *connection point*, as would be the case for a new *connection point*, an estimate based on the contract agreed maximum demand and other characteristics of the *load* would be used to allocate costs to that *connection point*.

6.10.2 Network support costs

An estimate of *network* support costs is converted to an equivalent asset replacement cost¹³ that is added to the asset replacement cost of the *transmission* assets these *network* support services support.

ElectraNet recovers these costs on a locational basis as part of its *modified CRNP methodology*.

Recovery of *network* support service costs on a locational basis is appropriate where the alternative *network augmentation* costs would be recovered on this basis.

¹³ Using the same rate of return that is subsequently used to determine *prescribed TUOS services* charges – locational component (*TUOS Usage* charges under old Rules).

6.11 Transmission prices and charges

6.11.1 Prescribed entry and exit services prices and charges

Prescribed entry services and *prescribed exit services* prices are calculated to recover the *prescribed entry* and *prescribed exit services ASRRs* from the *Network Users* who are served by the relevant *connection* assets.

The *prescribed entry services ASRR* is recovered as a fixed annual charge for each relevant *connection point*, which fixed annual charge is in turn recovered on the basis of a fixed \$/day entry price.

Similarly, the *prescribed exit services ASRR* is recovered as a fixed annual charge for each relevant *connection point*, which fixed annual charge is in turn is recovered on the basis of a fixed \$/day exit price.

6.11.2 Prescribed TUOS services – locational component prices and charges

Consistent with the provisions of clause 2.2(c)(1) of the *pricing methodology guidelines* locational prices will be determined on the basis of contract agreed maximum demand¹⁴.

The *prescribed TUOS services* locational *ASRR* described in section 0 is priced on a contract agreed maximum demand basis (\$/MW/day), where the contract agreed maximum demand is specified in, and re-negotiated in accordance with, customer *connection agreements*.

The *modified CRNP methodology* outlined in S6A.3 of the Rules and detailed in this proposed *pricing methodology* describes the process for cost allocation for the locational component of *prescribed TUOS services*, which results in a lump sum dollar amount to be recovered at each *connection point* as described in Appendix C.

This lump sum dollar amount for each *connection point* is divided by the product of the number of days in the forthcoming *financial year* and the contract agreed maximum demand (prevailing at the time *transmission* prices are published) to calculate the locational price for each *connection point*¹⁵ and is expressed as \$/MW/day.

As provided for under clause 6A.23.4(b)(2) of the Rules *prescribed TUOS services* locational prices must not change by more than 2% per annum at *connection points* relative to the *load* weighted average *prescribed TUOS services* locational price for the *region*. The balance of any revenue shortfall or *over-recovery amount* resulting from these price caps is recovered or offset as appropriate by adjusting the *prescribed TUOS services* non-locational prices and charges in accordance with clauses 6A.23.4(c) and 6A.23.4(d) of the Rules.

Locational prices are not subject to this limitation:

¹⁴ Referred to as the Agreed Maximum Demand (AMD) in ElectraNet *transmission connection agreements* (TCA). The methodology for dealing with exceedance of *contract agreed maximum demand* is as specified in *transmission connection agreements* and summarised in section 6.13.

¹⁵ The *connection point* for the purposes of determining the prescribed *TUOS prices* and prescribed *TUOS* charges will be the agreed point (or points) of supply between ElectraNet and the *transmission network user*. This is the point at which *contract agreed maximum demand* is defined in *transmission connection agreements* and historical or current metered *energy measured*.

- to the extent that the change in prices relate to the adjusted *modified load export change* per clause 6A.23.4(3)(i) of the Rules.
- Or, per clause 6A.23.4(3)(ii) of the Rules, if since the commencement of the previous *regulatory year*:
 - the *load* at the *connection point* has materially changed;
 - in connection with that change, the *Transmission Customer* requested a renegotiation of its *connection agreement* with the *Transmission Network Service Provider*; and
 - the *AER* has approved the change of more than 2 per cent per annum.

In the event that a *Transmission Customer* requests a material change in contract agreed maximum demand at an existing *connection point*, ElectraNet will seek approval from the *AER* to set the *prescribed TUOS services* – locational price without the limitation specified in clause 6A.23.4(b)(2) of the Rules.

Prescribed TUOS services locational charges are determined for each *connection point* providing prescribed *TUOS services* by multiplying the *prescribed TUOS services* locational price by the contract agreed maximum demand (prevailing during the *billing period* concerned) for that *connection point*, determined in accordance with the customer's *connection agreement*, and multiplying this amount by the number of days in the billing period.

For the avoidance of doubt forecast *prescribed TUOS services* locational charges will be calculated using the contract agreed maximum demand prevailing at the time prices are determined as distinct from the actual *prescribed TUOS services* locational charges which will be calculated using the contract agreed maximum demand prevailing during the billing period concerned.

Any *over-recovery amount* or *under recovery amount* arising from variances between forecast contract agreed maximum demands and the contract agreed maximum demands used for calculating *prescribed TUOS services* locational charges will be addressed by way of an *under-recovery amount* or an *over-recovery amount* adjustment when calculating prices for the following *financial year*.

6.11.3 ***Prescribed TUOS services* – non-locational component prices and charges**

Prices for recovery of the *adjusted non-locational component* of *prescribed TUOS services* are set on a postage-stamp basis in accordance with clause 6A.23.4(e) of the Rules.

Consistent with the provisions of clause 2.3(c)(1) of the *pricing methodology guidelines* prices on a postage-stamp bases are determined on the basis of contract agreed maximum demand or historical energy and calculated annually as follows.

Each *financial year* ElectraNet will determine the following two prices to apply at every *connection point*:

- an energy based price that is a price per unit of historical metered energy or current metered energy at a *connection point* expressed as \$/MWh; and

- a contract agreed maximum demand price that is a price per unit of contract agreed maximum demand at a *connection point* expressed as \$/MW/day.

Either the energy based price or the contract agreed maximum demand price will apply at a *connection point* providing *prescribed TUOS services* except for those *connection points* where a *Transmission Customer* has negotiated reduced charges for the adjusted non-locational component of *prescribed TUOS services* in accordance with clause 6A.26.1 of the Rules (prudent discounts).

The energy based price and the contract agreed maximum demand price is determined so that:

- a *Transmission Customer* with a *load factor* in relation to its *connection point* equal to the median *load factor* for *connection points* with *Transmission Customers* connected to the *transmission network* in the *region* or *regions* is indifferent between the use of the energy based price and the contract agreed maximum demand price; and
- the total amount to be recovered by the adjusted non-locational component of *prescribed TUOS services* does not exceed the *ASRR* for this category of *prescribed transmission service*.

When applying the energy based price, the *prescribed TUOS services* non-locational component charge for a *billing period* is calculated for each *connection point* by:

- multiplying the energy based price by the metered energy offtake at that *connection point* in the corresponding *billing period* two years earlier (i.e. historical metered energy offtake); or
- multiplying the energy based price by the metered energy offtake at that *connection point* in the same *billing period* (current metered energy offtake) if the historical metered energy offtake is unavailable; or
- multiplying the energy based price by the current metered energy offtake if the historical metered energy offtake is significantly different to the current metered energy off take. This method of calculation is only expected to be applied where the conditions necessary to enact clause 6A.23.4(3)(ii) of the Rules¹⁶ have been satisfied or a *connection point* is operated in a standby arrangement as detailed in section 6.12 of this proposed *pricing methodology*.

When applying the contract agreed maximum demand price, the *prescribed TUOS services* – non-locational component charge for a billing period will be calculated for each *connection point* by multiplying the contract agreed maximum demand price by the contract agreed maximum demand for the *connection point* (prevailing during the billing period concerned) and multiplying this amount by the number of days in the billing period.

For the avoidance of doubt forecast *prescribed TUOS services* non-locational charges will be calculated using the contract agreed maximum demand prevailing at the time prices are determined as distinct from the actual contract agreed maximum demand based charges which will be calculated using the contract agreed maximum demand prevailing during the billing period concerned.

¹⁶ That being the clause which allows for the relaxation of the side constraints on *TUOS* locational prices at a *connection point*.

Any *over-recovery amount* or *under-recovery amount* arising from variances between forecast *contract agreed maximum demands* and the contract agreed maximum demands used for calculating charges will be addressed by way of an *under-recovery amount* or *over-recovery amount* adjustment when calculating prices for the following *financial year*.

The energy based price or the contract agreed maximum demand price that applies for the adjusted non-locational component of *prescribed TUOS services* at a *connection point* will be the one which results in the lower estimated charge for that *prescribed transmission service*.

6.11.4 Prescribed common transmission service prices and charges

Prices for *prescribed common transmission services* are set on a postage-stamp basis in accordance with clause 6A.23.4(f) of the Rules.

Consistent with the provisions of clause 2.3(c)(1) of the *pricing methodology guidelines* postage stamped prices will be determined on the basis of contract agreed maximum demand or historical energy and calculated in a manner identical to that described for *prescribed TUOS services* non-locational charges in the previous section.

In accordance with clause 6A.23.3(h) of the Rules the operating and maintenance costs expected to be incurred in the provision of *prescribed common transmission services*, which are deducted from the *maximum allowed revenue* to form the *AARR*, are added to the *ASRR* for *prescribed common transmission services* and recovered through *prescribed common transmission service prices and charges*.

6.12 Standby service arrangements

This provision addresses the situation where ElectraNet has agreed to provide *prescribed transmission services* on a standby basis (such as to cover the *outage of onsite generation*).

If ElectraNet agrees to provide a standby service the customer's *connection agreement* must specify the terms and conditions applying to the provision of this service.

The customer's *connection agreement* would be required to specify the contract agreed maximum demand required to be available to the customer under normal operating conditions and a greater demand that may be sought on a standby basis subject to the operational condition of the *transmission network* at the time the standby arrangements are to be called on. The *transmission network* would be planned and developed to satisfy the contract agreed maximum demand rather than the standby demand.

The conditions to temporally vary from the contract agreed maximum demand must be specified in the customer's *connection agreement* and must ensure that compliance with the South Australian Electricity Transmission Code is maintained.

In this instance the customer will pay *prescribed exit services charges* (if applicable), *prescribed TUOS services* – locational component charges, *prescribed TUOS services* – non-locational component charges and *prescribed common transmission services* based:

- on the contract agreed maximum demand under normal operating conditions; and

- the standby demand and/or actual *energy* consumption during times that the standby service is actually utilised for *energy* delivery to the customer.

For the avoidance of doubt:

- where a standby service arrangement has been agreed between ElectraNet and the relevant customer, the customer's *connection agreement* must specify (amongst other things) a contract agreed maximum demand and the conditions under which an excess demand charge as detailed in section 6.13 will apply;
- where a customer's forecast agreed maximum demand¹⁷ results in the need to augment the *transmission network* access to the standby service arrangements may be withdrawn; and
- nothing in this section 6.12 obliges ElectraNet to agree to provide a standby service arrangement requested by a customer.

6.13 Excess demand charge

Subject to the provisions of section 6.12 where the customer's actual *maximum demand* exceeds the contract *agreed* maximum demand level at any time during the *financial year* then an excess demand charge applies and the actual *maximum demand* will become the contract agreed maximum demand, in accordance with the customer's *connection agreement*.

In addition, ElectraNet will recover from the customer the incremental charges the customer would have paid to ElectraNet during the entire *financial year* if the contract agreed maximum demand had been the actual *maximum demand*.

The excess demand charge is determined by multiplying the charge rate specified in ElectraNet's published Transmission Service Price Schedule (\$/kW) by the amount by which the contract agreed maximum demand has been exceeded (kW) or, where applicable, in accordance with the customer's *connection agreement*.

The charge rate (\$/kW) is calculated as three times the maximum revenue which ElectraNet can earn from *prescribed transmission services* during the pricing period (\$), divided by the aggregate of all contracted agreed maximum demands for customers *connected* to the *transmission network*.

6.14 Setting of prescribed TUOS services locational prices between annual price publications

In the event that ElectraNet is required to set a *prescribed TUOS services* locational price at a new *connection point* or at a *connection point* where the *load* has changed significantly after *prescribed TUOS service* locational prices have been determined and published, an interim price, not subject to the side constraints of clause 6A.23.4(f) of the Rules, will be determined. This will be calculated using the prevailing pricing models with demands estimated in a manner consistent with clause 2.2(f) of the *pricing methodology guidelines*.

A price subject to the side constraints of clause 6A.23.4(b)(2) of the Rules will be determined and published at the next annual price determination.

¹⁷ As defined in the Electricity Transmission Code

7. Billing Arrangements

7.1 Billing for prescribed transmission services

Consistent with clause 6A.27.1 of the Rules, ElectraNet will calculate the *transmission service charges* payable by *Transmission Network Users* for each *connection point* in accordance with the *transmission service prices* published under clause 6A.24.2 of the Rules.

Where charges are determined for *prescribed transmission services* from *metering data*, these charges will be based on kW or kWh obtained from the *metering data* managed by AEMO.

ElectraNet will issue invoices to *Transmission Network Users* for *prescribed transmission services* which satisfy or exceed the minimum information requirements specified in clause 6A.27.2 of the Rules on a monthly basis or as specified in the *transmission connection agreement*.

Consistent with clause 6A.27.3 of the Rules a *Transmission Network User* must pay charges for *prescribed transmission services* properly charged to it and billed in accordance with this proposed *pricing methodology* by the date specified on the invoice.

7.2 Payments between Transmission Network Service Providers

Consistent with clause 6A.27.4 of the Rules, where ElectraNet is the *Co-ordinating Network Service Provider* under clause 6A.29.1 of the Rules, it will pay to each other relevant *Transmission Network Service Provider* the revenue which is estimated to be collected during the following year by ElectraNet as charges for *prescribed transmission services* for the use of *transmission systems* owned by those other *Transmission Network Service Providers*.

Such payments will be determined by ElectraNet as the *Co-ordinating Network Service Provider* for the *region*.

Financial transfers payable under clause 6A.27.4 of the Rules will be paid in equal monthly instalments or as documented in revenue collection agreements negotiated between the parties.

8. Prudential Requirements

8.1 Prudential requirements for prescribed transmission services

Consistent with clause 6A.28.1 of the Rules, ElectraNet may require a *Transmission Network User* to establish *prudential requirements* for either or both *connection services* and *transmission use of system services*. These *prudential requirements* may take the form of, but need not be limited to, capital contributions, pre-payments or financial guarantees.

The requirements for such *prudential requirements* will be negotiated between the parties and specified in the applicable *transmission connection agreement*.

8.2 Capital contribution or prepayment for a specific asset

ElectraNet notes that no capital contributions or prepayments have been made in respect of *prescribed transmission services* assets as at the date of this proposed *pricing methodology*.

Consistent with clause 6A.28.2 of the Rules, where ElectraNet is required to construct or acquire specific assets to provide *prescribed connection services* or *prescribed TUOS services* to a *Transmission Network User*, ElectraNet may require that *Transmission Network User* to make a capital contribution or prepayment for all or part of the cost of the new assets installed.

In the event that a capital contribution is required, any contribution made will be taken into account in the determination of *prescribed transmission service* prices applicable to that *Transmission Network User* by way of a proportionate reduction in the ORC of the asset(s) used for the allocation of *prescribed transmission service* charges or as negotiated between the parties.

In the event that a prepayment is required any prepayment made will be taken into account in the determination of *prescribed transmission service* prices applicable to that *Transmission Network User* in a manner to be negotiated between the parties.

The treatment of such capital contributions or prepayments for the purposes of a *revenue determination* will in all cases be in accordance with the relevant provisions of the Rules.

9. Prudent Discounts

ElectraNet may, but is not required to, agree with a *Transmission Customer* to charge lower prices for the non-locational component of *prescribed TUOS services* and *prescribed common transmission services* provided to that *Transmission Customer*, than the prices determined in accordance with this proposed *pricing methodology*.

ElectraNet notes that none of its *Transmission Customers* currently receive prudent discounts as at the date of this proposed *pricing methodology*.

In the event that a *Transmission Customer* does receive prudent discounts in the future, ElectraNet will, in accordance with clause 6A.26.1(d)-(g) of the Rules, adjust the adjusted non-locational component of *prescribed TUOS services*; and the *prescribed common transmission services* prices and charges to other customers for the amount of any anticipated *under-recovery amount* arising from prudent discounts applied.

10. Monitoring and Compliance

As a regulated business ElectraNet is required to maintain extensive compliance monitoring and reporting systems to ensure compliance with its Transmission Licence, *revenue determination*, the Electricity Transmission Code and the Rules together with numerous other legislative obligations.

In order to monitor and maintain records of its compliance with its approved pricing methodology, the *Pricing Principles for Prescribed Transmission Services*, and Part J of the Rules, ElectraNet proposes to:

- Maintain the specific obligations arising from Part J of the Rules in its compliance management system;
- Maintain electronic records of the annual calculation of *prescribed transmission service* prices and supporting information; and
- Periodically subject its transmission pricing models and processes to functional audit by suitably qualified persons.

11. Differences between current and proposed *pricing methodologies*

This proposed *pricing methodology*, applicable from 1 July 2013 to 30 June 2018, proposes minor amendments to:

- reflect the changes to the Rules that have occurred subsequent to the approval of the current *pricing methodology*, specifically the Rule change of January 2010 which varied the provisions of clause 11.6.11 of the Rules; and
- modifications to the standby provisions of section 6.12 to encourage customers to better manage their peak demand and reduce their impact on the *transmission network* at times of high network utilisation.

12. Additional Information Requirements

A number of additional information requirements arise from the *pricing methodology guidelines* which have not been covered elsewhere in this revised proposed *pricing methodology*. In order to satisfy these requirements ElectraNet notes that it does not:

- consider transitional arrangements are necessary as a result of the implementation of the proposed *pricing methodology*;
- have any applicable relevant *derogations* in accordance with chapter 9 of the Rules; or
- have any applicable transitional arrangements arising from chapter 11 of the Rules.

ElectraNet has not provided a confidential version of this proposed *pricing methodology* to the AER in accordance with clause 2.5 of the *pricing methodology guidelines* and hence the provisions of clause 2.1(n) of the *pricing methodology guidelines* are not applicable.

13. Conclusion

ElectraNet's proposed *pricing methodology* for the *regulatory control period* from 1 July 2013 to 30 June 2018 has been submitted to the AER in accordance with the requirements of Chapter 6A of the Rules and the *pricing methodology guidelines*.

ElectraNet is confident that this proposed *pricing methodology* fully satisfies the requirements of the Rules and the *pricing methodology guidelines*.

Appendix A Structure of Transmission Pricing under Part J of Rules

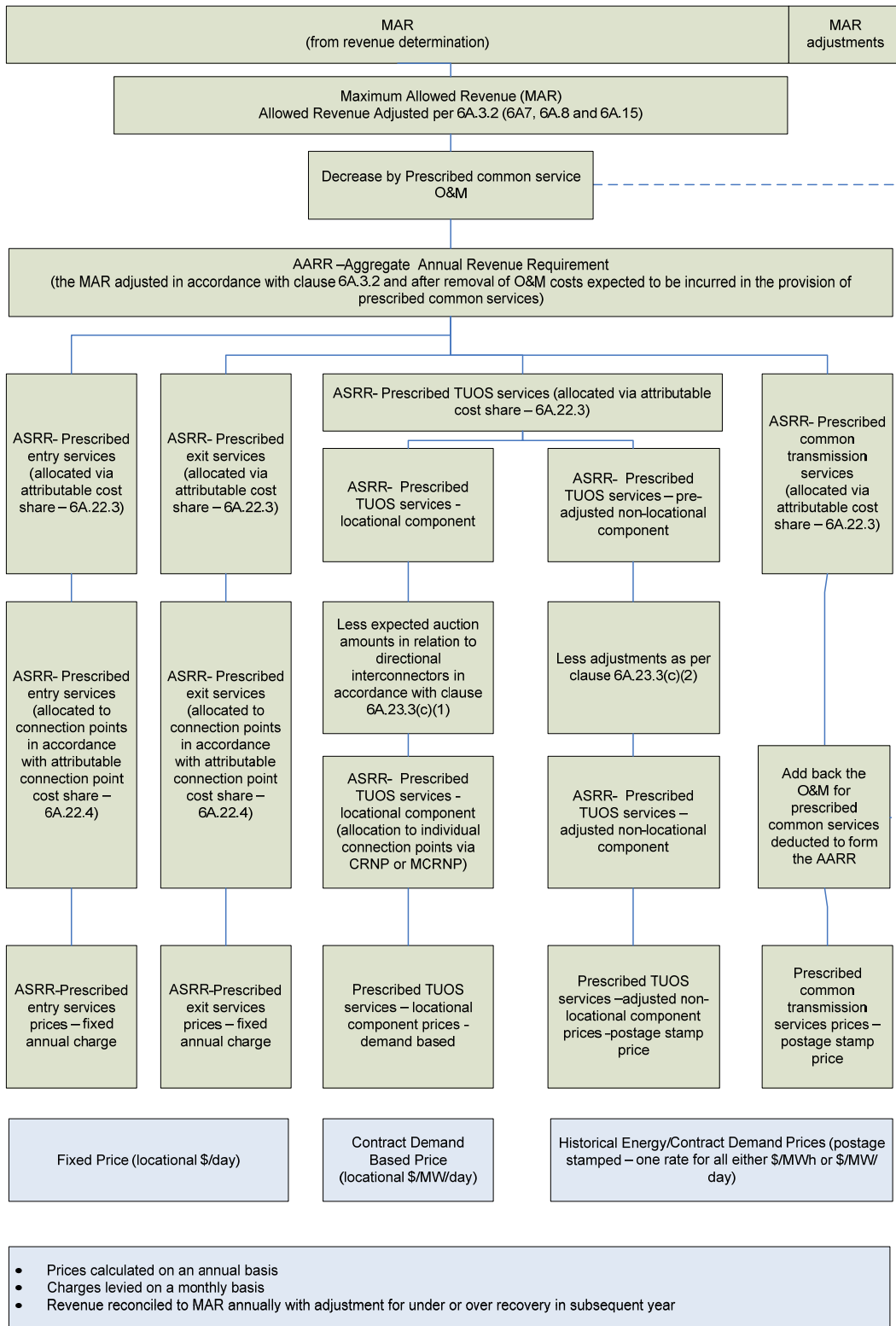

Appendix B Details of Cost Allocation Process

A detailed cost allocation process is used to assign the optimised replacement cost (ORC) of all *prescribed transmission service* assets to either *prescribed common Transmission services* (assets that benefit all *Transmission Customers*), *network branches (transmission lines or transformers)*¹⁸ and *prescribed entry services* or *prescribed exit services* in a manner consistent with Section 2.4 of the *pricing methodology guidelines*.

The cost allocation process is summarised as follows:

Step 1: Initial Cost Allocation

Assets and their ORCs are assigned to one of the following primary asset categories:

- *transmission lines*;
- *transformers*;
- circuit breakers;
- common service assets (communications, reactive support, office buildings etc.); and
- *substation* local assets (ancillary equipment, civil work, and establishment).

The following plant items are not separately identified in the ORC database and are incorporated into the ORC of the associated primary items above:

- bus work;
- secondary systems including protection and instrument transformers.

Step 2: Allocation to *Categories of Transmission Services*

Assets are allocated to the *categories of prescribed transmission services* in accordance with the provisions of Section 2.4 of the *pricing methodology guidelines*. In the case of circuit breakers each circuit breaker has its replacement cost divided evenly between the branches to which it is directly attributable. Any circuit breaker that is not directly attributable to any branch together with *substation* local costs identified in step 1 are subject to the priority ordering process.

In the case of a shared *connection asset*, such as a *transformer*, serving multiple *connection points* which may provide both *prescribed entry services* and *prescribed exit services* the cost of the shared *connection asset* will be allocated to the appropriate category or categories of *prescribed transmission services* using an appropriate cost allocator¹⁹. For example:

- *Generation* or reactive plant nameplate rating capacity or agreed maximum demand (AMD) supplied by the specified transmission category of *prescribed transmission services* as a percentage of the total capacity and demand of all categories of *prescribed transmission services* at that location: Costs are attributable based on the capacity and/or AMD agreed upon by the customer(s);

¹⁸ ElectraNet maintains an optimised replacement cost (ORC) model of the *transmission network* to determine the appropriate ORC of individual *transmission lines*, *transformers*, circuit breakers, *common service* assets and *substation* local costs.

¹⁹ This is consistent with ElectraNet's proposed *Cost Allocation Methodology* which is used to allocate costs between *prescribed transmission services*, *negotiated transmission services* and *non-regulated transmission services*.

- Unit of plant method: Costs are allocated based on the number of units of plant installed (typically circuit breakers) where these units of plant can be attributed to a particular category of *prescribed transmission service*; or
- As negotiated between the connecting parties.

This process would also be adopted to allocate shared costs to individual *connection points*.

Step 3: Priority Ordering

In the case of those costs which would be attributable to more than one category of *prescribed transmission services*, specifically the *substation* local assets identified in Step 1 and those circuit breakers identified as *substation* local costs in Step 2, costs will be allocated in accordance with the provisions of clause 6A.23.2(d) of the Rules having regard to the *stand-alone amount* costs associated with the provision of *prescribed TUOS services* and *prescribed common transmission services* with the remainder being allocated to *prescribed entry services* and *prescribed exit services*. The implementation of the priority ordering process is detailed in Appendix E.

Conclusion

The shared *network costs* resulting from the cost allocation process are used as input to TPRICE, the *Cost Reflective Network Pricing* software that is approved by the AER for use by TNSPs in the *NEM*.

The *entry cost*, *exit cost* and *common service* costs are used as input to the calculation of *prescribed entry services* prices, *prescribed exit services* prices and *prescribed common transmission services* prices.

Appendix C Cost Reflective Network Pricing Methodology

The *cost reflective network pricing methodology (CRNP methodology)* involves the following steps:

- Determining the annual costs of the individual *transmission network* assets in the optimised *transmission network*;
- For a *modified CRNP methodology*, adjusting each asset's cost according to its expected utilisation;
- Determining the proportion of each individual *network element* utilised in providing a *transmission service* to each point in the *network* for specified operating conditions;
- Determining the maximum flow imposed on each *transmission element* by *load* at each *connection point* over a set of operating conditions;
- Allocating the costs attributed to the individual *transmission elements* to *loads* based on the proportionate use of the elements; and
- Determining the total cost (lump sum) allocated to each point by adding the share of the costs of each individual *network element* attributed to each point in the *network*.

Allocation of Generation to Load

A major assumption in the use of the *CRNP methodology* is the definition of the *generation* source and the point where *load* is taken. The approach is to use the "electrical distance" to pair *generation* to *load*, in which a greater proportion of *load* at a particular location is supplied by *Generators* that are electrically closer than those that are electrically remote. In electrical engineering terminology the "electrical distance" is the impedance between the two locations, and this can readily be determined through a standard engineering calculation called the "fault level calculation".

Once the assumption has been made as to the *Generators* that are supplying each *load* for a particular *load* and *generation* condition (time of day) it is possible to trace the flow through the *network* that results from supplying each *load* (or *Generator*). The use made of any element by a particular *load* is then simply the ratio of the flow on the element resulting from the supply to this *load* to the total use of the *load* made by all *loads* and *Generators* in the *power system*.

Operating Conditions for Cost Allocation

The choice of operating conditions is important in developing prices using the *CRNP methodology* or *modified CRNP methodology*. ElectraNet has flexibility in the choice of operating conditions but notes that the old NER set out the principles that should apply in determining the sample of operating conditions considered. Of particular note is the requirement that the operating conditions to be used are to include at least 10 days with high system demand, to ensure that loading conditions, which impose peak flows on all *transmission elements*, are captured.

Schedule 6A.3.2(3) of the Rules is less prescriptive requiring that the allocation of *dispatched generation* to *loads* be over a range of actual operating conditions from the previous *financial year* and that the range of operating scenarios is chosen so as to include the conditions that result in most stress on the *transmission network* and for which *network* investment may be contemplated.

In selecting those operating scenarios it is important to recognise that the operating conditions that impose most stress on particular elements may occur at times other than for system peak demand.

Appendix D Ratings Adjustment for Calculating Utilisation Factors

When assigning a proportion of shared *network* costs to individual *customer connection points* the *modified CRNP methodology* reduces the ORC of each shared *network* pricing branch (line or *transformer*) by a utilisation factor that reflects the maximum loading of the branch with respect to its rating.

In determining the appropriate branch rating for entry into TPRICE (used to perform the *CRNP* calculations) it is important to understand that TPRICE only considers system normal operating conditions whereas the shared *network* must be able to withstand a single contingency *outage* without overloading any *network element* consistent with the requirements of the Rules and the South Australian Electricity Transmission Code.

This means that utilisation factors calculated with respect to equipment ratings (thermal line ratings and transformer nameplate ratings) under system normal conditions would result in artificially low utilisation factors.

This problem can be overcome by reducing the equipment ratings to reflect the maximum flow on a *network* branch under system normal conditions that would not result in its absolute rating being exceeded in the event of the worst contingency.

The reduced ratings are calculated by examining flows in *network elements* over a range of peak system operating conditions first for system normal conditions, and then with each meshed *network element* out of service one at a time. For each *network element*, the ratio of maximum system normal flow to maximum contingency flow is used to scale down the absolute equipment rating to obtain the reduced rating for input to TPRICE.

This rating adjustment is consistent with Schedule 6.4.1.6(b) of the old Rules, which states in relation to a *modified CRNP methodology* that “*The asset utilisation is to be based on the maximum flow allowed on elements within the normal operating constraints of the network*”.

This process can best be illustrated by an example. A line has an absolute (thermal) rating of 200 MV.A. *Network* analysis over a range of peak operating conditions shows that this line has a maximum system normal flow of 120 MV.A and a maximum single contingency flow of 160 MV.A. The reduced rating of this line (as input to TPRICE) is $(120/160) * 200$ giving 150 MV.A.

When TPRICE is run, analysis will consider flows on this line over a much wider range of operating conditions (than used in the contingency analysis) some of which may even exceed 120 MV.A. If say the highest usage of this line over the operating conditions assessed by TPRICE is 123 MV.A, then the utilisation factor used by TPRICE with *modified CRNP* will be 0.82 (123/150).

Appendix E Priority Ordering Methodology

Rules Requirements

Clause 6A.23.2 (d) of the Rules requires that:

Where, as a result of the application of the *attributable cost share*, a portion of the AARR would be attributable to more than one *category of prescribed transmission services*, that *attributable cost share* is to be adjusted and applied such that any costs of a *transmission system* asset that would otherwise be attributed to the provision of more than one category of *prescribed transmission services*, is allocated as follows:

- (1) to the provision of *prescribed TUOS services*, but only to the extent of the *stand-alone amount* for that *category of prescribed transmission services*;
- (2) if any portion of the costs of a *transmission system* asset is not allocated to *prescribed TUOS services*, under subparagraph (1), that portion is to be allocated to *prescribed common transmission services*, but only to the extent of the *stand-alone amount* for that *category of prescribed transmission services*; and
- (3) if any portion of the costs of a *transmission system* asset is not attributed to *prescribed transmission services* under subparagraphs (1) and (2), that portion is to be attributed to *prescribed entry services* and *prescribed exit services*.

Stand-alone amount is defined as:

For a category of *prescribed transmission services*, the costs of a *transmission system* asset that would have been incurred had that *transmission system* asset been developed, exclusively to provide that *category of prescribed transmission services*.

Transitional Rule 11.6.11(c) states the following:

“For the purposes of new Chapter 6A:

- (1) the costs of the *transmission system* assets that from time to time may be treated as:
 - (i) directly attributable to the provision of a prescribed connection service; or
 - (ii) incurred in providing a prescribed connection service,
to a *Transmission Network User* or a group of *Transmission Network Users* at a *transmission network connection point* is limited to the costs of the eligible assets which, from time to time, provide that prescribed connection service;
- (2) any costs of an existing asset or a replacement asset (or of any portion of an existing asset or a replacement asset) that:
 - (i) is not an eligible asset (other than as a result of clause 11.6.11(d)); and
 - (ii) is used by a *Transmission Network Service Provider* to provide connection services to a *Transmission Network User* or a group of *Transmission Network Users* at a *transmission network connection point*,

must be treated as costs that are directly attributable to the provision of, or are incurred in providing, *prescribed TUOS services* and, to avoid doubt, the services provided by those assets which would otherwise be *connection services* are taken to be *prescribed TUOS services*; and

- (3) the *stand-alone amount* for *prescribed TUOS services* is taken to include any portion of the costs referred to in clause 11.6.11(c)(2) that has not been allocated under clause 6A.23.2(d)(1).”

This transitional provision effectively introduces a fourth step to the priority ordering requirement

Objective and General Approach

The allocation methodology relies on the assumption that *substation* infrastructure and establishment costs are proportionate to the number of *high-voltage* circuit breakers in the *substation*.

Based on this assumption the appropriate allocator for *substation* infrastructure and establishment costs for a stand-alone arrangement is the ratio of the number of *high voltage* circuit breakers²⁰ in the stand-alone arrangement to the number of *high voltage* circuit breakers in the whole *substation*.

Proposed Methodology

Step 1: Branch Identification

Identify the branches²¹, being the lines, *transformers*, major reactive devices and exits/entries in the *substation* which provide *prescribed TUOS services*, *prescribed common transmission services* and *prescribed exit services* or *prescribed entry services*, in the *substation*.

Step 2: Allocation of Circuit Breakers to Branches

For each *high voltage* circuit breaker in the *substation* identify the branches directly *connected* to it. Any circuit breaker that does not directly *connect* to a branch is excluded from allocation and all costs associated with it are added to the *substation* infrastructure and establishment cost.

Count the total number of circuit breakers directly *connected* to branches.

Distribution Network Service Providers (DNSPs) are classified as a *prescribed exit service* while *Generators* are classified as a *prescribed entry service*. *Negotiated transmission services* are not part of the regulated asset base and fall outside the priority ordering process detailed in clause 6A.23.2(d) of the Rules.

²⁰ Low voltage circuit breakers are not considered in the standalone arrangements.

²¹ Described in Definition – Branches.

Step 3.1: Stand-alone arrangements for prescribed TUOS services

With reference to the number of lines providing *prescribed TUOS services* determine the number of circuit breakers required to provide *prescribed TUOS services* of an equivalent standard on a stand-alone basis²². The stand-alone configuration is the simplest *substation* configuration (in the absence of development) had it been developed to provide a *prescribed TUOS service*. This may be done by way of a look up of typical stand-alone configurations.

Step 3.2: Stand-alone arrangements for Prescribed common transmission services

With reference to the number of lines providing *prescribed TUOS services* and the devices providing *prescribed common transmission service* determine the number of circuit breakers required to provide *prescribed common transmission services* of an equivalent standard on a stand-alone basis. The stand-alone configuration is the simplest *substation* configuration (in the absence of development) had it been developed to provide a *prescribed common transmission service*. This may be done by way of a look up of typical stand-alone configurations.

Step 4: Allocation of substation infrastructure and establishment costs

Step 4.1 Allocation of prescribed TUOS services

Allocate a portion of *substation* infrastructure and establishment costs to *prescribed TUOS services* according to the ratio of the *high voltage* circuit breakers identified in step 3.1 to the total number of *high voltage* circuit breakers *connected* to branches in the *substation* identified in step 2.

Step 4.2 Calculation of the Unallocated Substation Infrastructure Costs (after prescribed TUOS service Allocation)

Calculate the unallocated substation infrastructure cost (after *prescribed TUOS services allocation*) by subtracting the amount calculated in step 4.1 from the total *substation* infrastructure amount.

Step 4.3 Allocation of Prescribed Common Transmission Service

Allocate a portion of the *substation* infrastructure and establishment costs to *prescribed common transmission services* based on to the ratio of the *high voltage* circuit breakers providing *prescribed common transmission services* identified in step 3.2 to the total number of *high voltage* circuit breakers *connected* to branches in the *substation*. If the *prescribed common transmission services* portion of *substation* infrastructure is greater than the unallocated costs, then the unallocated portion only is attributed to *prescribed common transmission services*. In this instance, nothing will be attributed to *prescribed entry services* and *prescribed exit services*.

Step 4.4 Calculation of the Unallocated Substation Infrastructure Costs (after prescribed common transmission service Allocation)

Calculate the unallocated *substation* infrastructure cost (after *prescribed common transmission services* allocation) by subtracting the amount calculated in step 4.3 from the amount calculated in step 4.2.

²² A *substation* would typically not exist to provide *prescribed TUOS services* alone, however this interpretation is inconsistent with the intent of the Rule. Accordingly standalone arrangements for *prescribed TUOS services* are taken to require a level of switching consistent with the prevailing bus arrangements.

Step 4.5 Allocation of Prescribed Entry and Exit Service costs to Prescribed TUOS services per 11.6.11

Allocate the remaining *substation* infrastructure and establishment costs (calculated in step 4.4) to each branch providing *prescribed TUOS services* based on the ratio of the *high voltage* circuit breakers providing the *prescribed TUOS services* to the branch to the total number of *high voltage* circuit breakers providing *prescribed TUOS services* or in accordance with the cost allocation process in Appendix B as appropriate.

Notes

Costs are only allocated in step 4 until fully allocated.

Consistent with clause 6A.23.2(d)(3) of the Rules it is possible that no costs will be attributed to *prescribed entry services* and *prescribed exit services*.

New and existing *negotiated transmission service* assets are excluded from the analysis as any incremental establishment costs associated with them are taken to be included in the *negotiated transmission services* charges on a causation basis.

The assessment of standalone arrangements only needs to be conducted once per substation except where changes to the configuration of the substation occur.

Definition – Branches

As illustrated by the diagrams below a “Branch” is a collection of assets (e.g. lines, circuit breakers, capacitors, buses and *transformers*) that provide a *transmission service*.

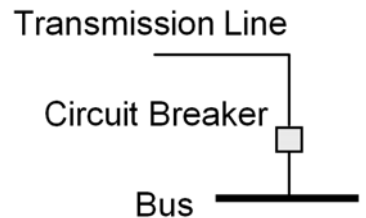

Branch with Transmission Line, Bus and Circuit Breaker

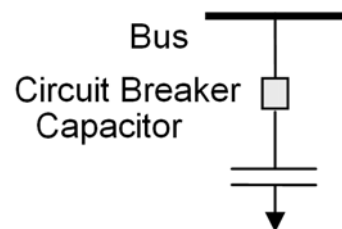

Branch with Capacitor, Circuit Breaker and Bus

Examples

Example A

Substation Configuration

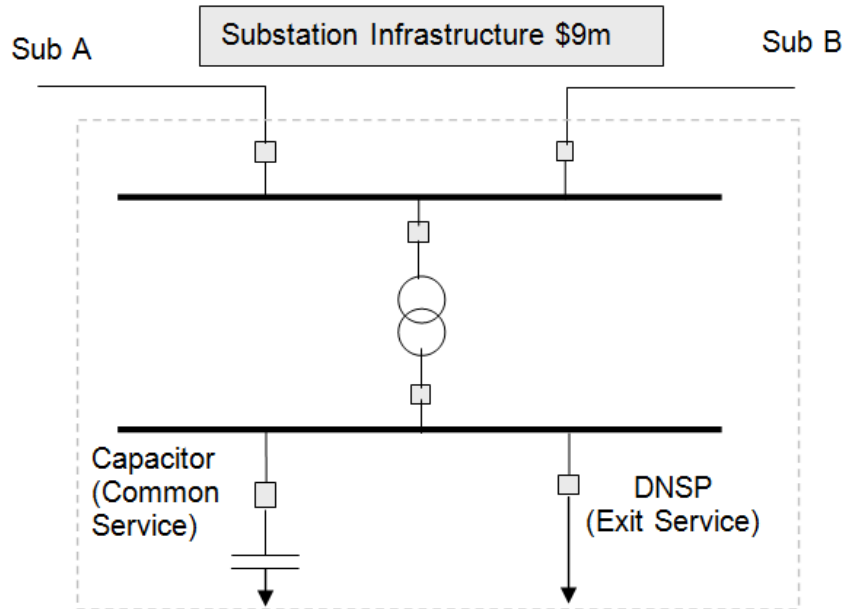

- Step 1: The branches are Sub A, Sub B, DNSP, Tie Transformer and *prescribed common transmission services*.
- Step 2: The total number of circuit breakers directly *connected* to branches is 6.
- Step 3.1: The stand-alone arrangement for the provision of *prescribed TUOS services* to an equivalent standard is shown below and consists of 2 circuit breakers.

Stand Alone Prescribed TUOS Service



- Step 3.2: The stand-alone arrangement for the provision of *prescribed common transmission services* to an equivalent standard is shown below and consists of 3 circuit breakers.

Stand Alone Prescribed Common Transmission Service

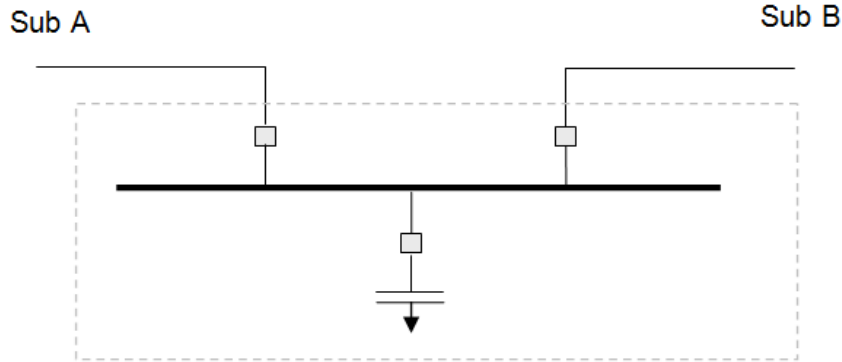

Step 4:

Assume total Infrastructure cost is \$9m.

Costs are allocated to *prescribed TUOS services* in the ratio of the circuit breakers in the stand-alone arrangement to the total circuit breakers.

Infrastructure Cost Allocated to *prescribed TUOS services* = $(2/6) \times \$9m = \$3m$

Unallocated Substation Infrastructure Costs (after *prescribed TUOS services* allocation) = $\$9m - \$3m = \$6m$

Costs are allocated to *prescribed common transmission services* in the ratio of the circuit breakers in the stand-alone arrangement to the total circuit breakers.

Infrastructure Cost allocated to *prescribed common transmission services* = $(3/6) \times \$9m = \$4.5m$

Unallocated Substation Infrastructure Costs (after *prescribed common transmission service* allocation)
= $\$6m - \$4.5m = \$1.5m$

Remainder of unallocated (calculated above) to be allocated to *prescribed TUOS services* per clause 11.6.11 of the Rules

Infrastructure Cost allocated to *prescribed TUOS services* = \$1.5m

Item	Number	Allocation	Unallocated
Substation infrastructure costs		9,000,000	9,000,000
Total Breakers	6		
TUOS Stand-alone breakers	2		
Share to TUOS (a)	0.333	3,000,000	6,000,000
Common Service stand-alone breakers	3		
Share to Common Service	0.500	4,500,000	1,500,000
Share to TUOS (b)		1,500,000	
Total Share to TUOS (a) + (b)		4,500,000	
Total Share to Common Service		4,500,000	

Example B

Substation Configuration

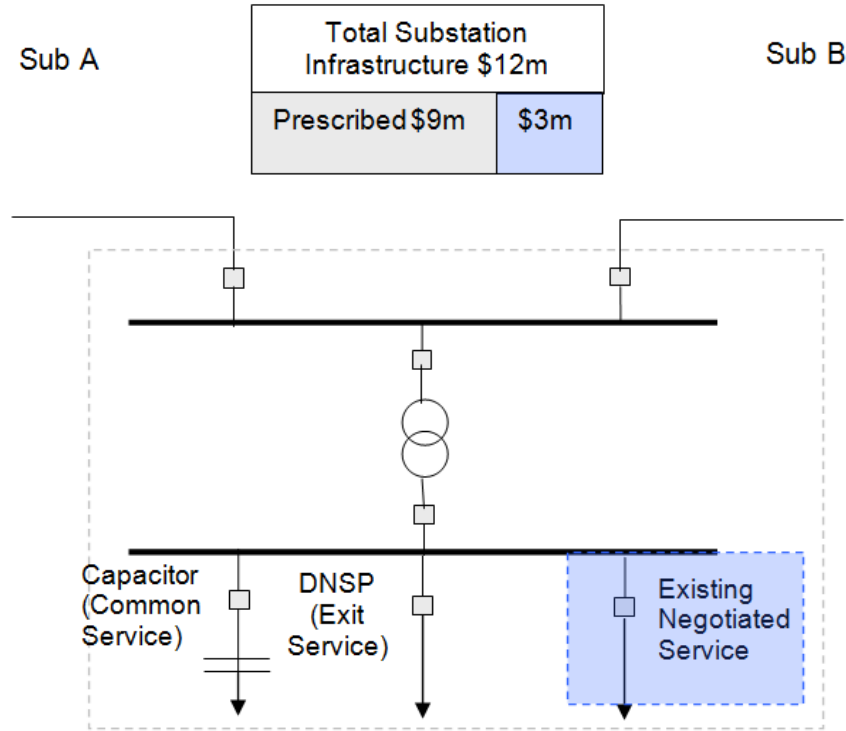

- Step 1: The branches are Sub A, Sub B, DNSP, Tie Transformer, *prescribed common transmission services* and an existing negotiated service.
- Step 2: The total number of circuit breakers directly *connected* to branches is 6 (no prescribed costs are allocated to the existing *negotiated transmission service*).
- Step 3.1: The stand-alone arrangement for the provision of *prescribed TUOS services* to an equivalent standard is shown below and consists of 2 circuit breakers.

Stand Alone Prescribed TUOS Services



- Step 3.2: The stand-alone arrangement for the provision of *prescribed common transmission services* to an equivalent standard is shown below and consists of 3 circuit breakers.

Stand Alone Prescribed Common Transmission Services

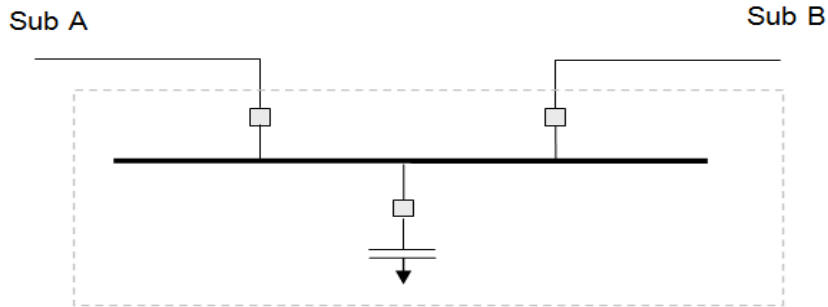

Step 4:

Assume total Infrastructure cost is \$12m, however \$3m is for the existing *negotiated transmission service*, which does not form part of the regulated asset base and is not governed by clause 6A.23.2(d) of the Rules.

Costs are allocated to *prescribed TUOS services* in the ratio of the circuit breakers in the stand-alone arrangement to the total circuit breakers.

Infrastructure Cost Allocated to *prescribed TUOS services* = $(2/6) \times \$9m = \$3m$

Unallocated Substation Infrastructure Costs (after *prescribed TUOS services* allocation) = $\$9m - \$3m = \$6m$

Costs are allocated to *prescribed common transmission services* in the ratio of the circuit breakers in the stand-alone arrangement to the total circuit breakers.

Infrastructure Cost allocated to *prescribed common transmission services* = $(3/6) \times \$9m = \$4.5m$

Unallocated Substation Infrastructure Costs (after *prescribed common transmission services* allocation)
= $\$6m - \$4.5m = \$1.5m$

Remainder of unallocated (calculated above) to be allocated to *prescribed TUOS services*.

Infrastructure Cost allocated to *prescribed TUOS services* = $\$1.5m$

Item	Number	Allocation	Unallocated
Substation infrastructure costs		9,000,000	9,000,000
Total Breakers	6		
TUOS Stand-alone breakers	2		
Share to TUOS (a)	0.333	3,000,000	6,000,000
Common Service stand-alone breakers	3		
Share to Common Service	0.500	4,500,000	1,500,000
Share to TUOS (b)		1,500,000	
Total Share to TUOS		4,500,000	
Total Share to Common Service		4,500,000	

Example C

Substation Configuration

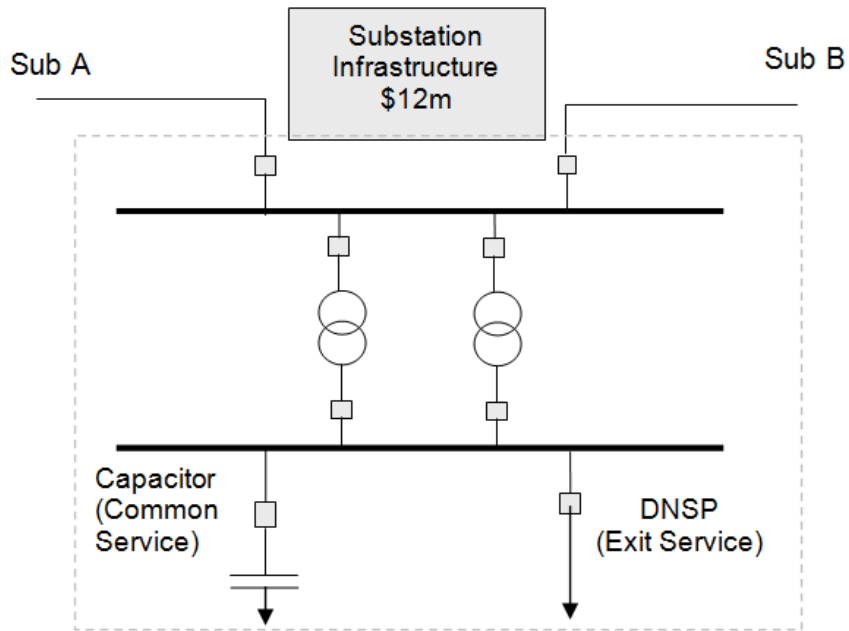

- Step 1: The branches are Sub A, Sub B, DNSP, Tie Transformer 1, Tie Transformer 2 and *prescribed common transmission service*.
- Step 2: The total number of circuit breakers directly *connected* to branches is 8.
- Step 3.1: The stand-alone arrangement for the provision of *prescribed TUOS services* to an equivalent standard is shown below and consists of 2 circuit breakers.

Stand Alone Prescribed TUOS services



- Step 3.2: The stand-alone arrangement for the provision of *prescribed common transmission services* to an equivalent standard is shown below and consists of 3 circuit breakers.

Stand Alone Prescribed Common Transmission Service

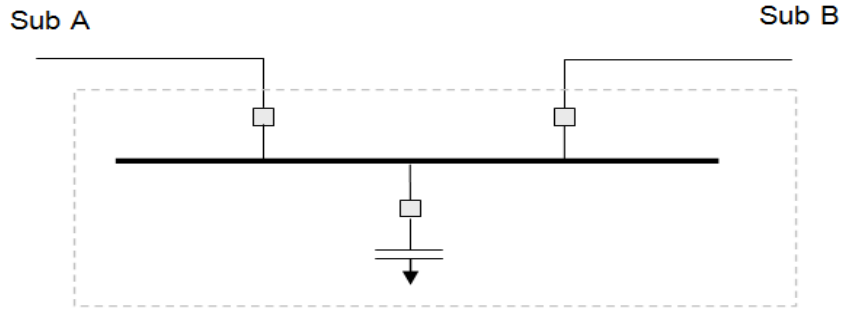

Step 4:

Assume total Infrastructure cost is \$12m.

Costs are allocated to *prescribed TUOS services* in the ratio of the circuit breakers in the stand-alone arrangement to the total circuit breakers.

Infrastructure Cost Allocated to *prescribed TUOS services* (a) = $(2/8) \times \$12m = \$3m$

Unallocated Substation Infrastructure Costs (after *prescribed TUOS services* allocation) = $\$12m - \$3m = \$9m$

Costs are allocated to *prescribed common transmission service* in the ratio of the circuit breakers in the stand-alone arrangement to the total circuit breakers.

Infrastructure Cost allocated to *prescribed common transmission services* = $(3/8) \times \$12m = \$4.5m$

Unallocated Substation Infrastructure Costs (after *prescribed common transmission services* allocation)
= $\$9m - \$4.5m = \$4.5m$

Remainder of unallocated (calculated above) to be allocated to *prescribed TUOS services*.

Infrastructure Cost allocated to *prescribed TUOS services* (b) = $\$4.5m$

Item	Number	Allocation	Unallocated
Substation infrastructure costs		12,000,000	12,000,000
Total Breakers	8		
TUOS Stand-alone breakers	2		
Share to TUOS (a)	0.250	3,000,000	9,000,000
Common Service stand-alone breakers	3		
Share to Common Service	0.375	4,500,000	4,500,000
Share to TUOS (b)		4,500,000	
Total Share to TUOS		7,500,000	
Total Share to Common Service		4,500,000	

Example D

Substation Configuration

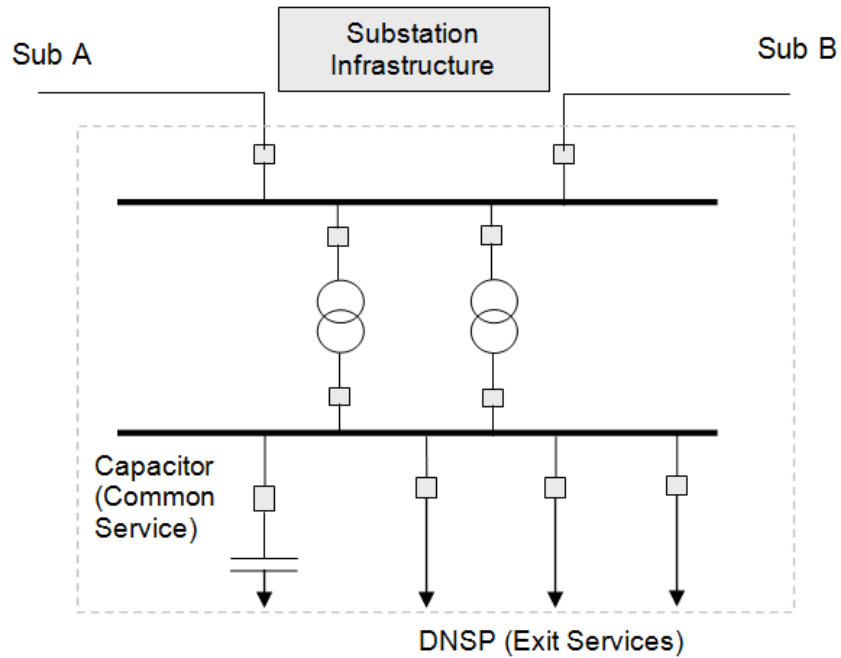

- Step 1: The branches are Sub A, Sub B, *DNSP1*, *DNSP2*, *DNSP3*, Tie Transformer 1, Tie Transformer 2 and PCS.
- Step 2: The total number of circuit breakers directly *connected* to branches is 10.
- Step 3.1: The stand-alone arrangement for the provision of *prescribed TUOS services* to an equivalent standard is shown below and consists of 2 circuit breakers.

Stand Alone Prescribed TUOS services



- Step 3.2: The stand-alone arrangement for the provision of *prescribed common transmission services* to an equivalent standard is shown below and consists of 3 circuit breakers.

Stand Alone Prescribed Common Transmission Service

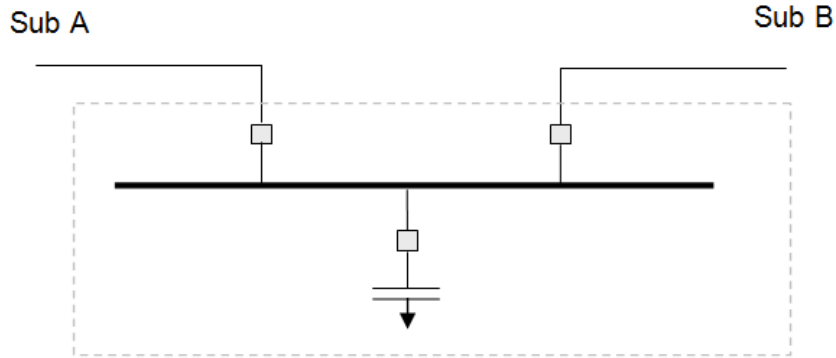

Step 4:

Assume total Infrastructure cost is \$15m.

Costs are allocated to *prescribed TUOS services* in the ratio of the circuit breakers in the stand-alone arrangement to the total circuit breakers.

Infrastructure Cost Allocated to *prescribed TUOS services* (a) = $(2/10) \times \$15m = \$3m$

Unallocated Substation Infrastructure Costs (after *prescribed TUOS services* allocation) = $\$15m - \$3m = \$12m$

Costs are allocated to *prescribed common transmission services* in the ratio of the circuit breakers in the stand-alone arrangement to the total circuit breakers.

Infrastructure Cost allocated to *prescribed common transmission service* = $(3/10) \times \$15m = \$4.5m$

Unallocated Substation Infrastructure Costs (after *prescribed TUOS services* allocation) = $\$12m - \$4.5m = \$7.5m$

Remainder of unallocated (calculated above) to be allocated to *prescribed TUOS services*.

Infrastructure Cost allocated to *prescribed TUOS services* (b) = \$7.5m

Item	Number	Allocation	Unallocated
Substation infrastructure costs		15,000,000	15,000,000
Total Breakers	10		
TUOS Stand-alone breakers	2		
Share to TUOS (a)	0.200	3,000,000	12,000,000
Common Service stand-alone breakers	3		
Share to Common Service	0.300	4,500,000	7,500,000
Share to TUOS (b)		7,500,000	
Total Share to TUOS		10,500,000	
Total Share to Common Service		4,500,000	

Appendix F Inter-regional Transmission Charging

1. Introduction

As the appointed *Co-ordinating Network Service Provider* referred to in Clause 6A.29.1 of the Rules, ElectraNet will calculate the *AARR* for the SA region; and will calculate, bill and arrange for the payment of the *modified load export charge (MLEC)* in accordance with 6A.29A of the Rules and the Section 2.6 of the AER's guidelines.

ElectraNet will publish details of all *modified load export charges* to apply in the following financial year on its website by 15 March each year consistent with clause 6A.24.2(b) of the Rules.

The inter-regional transmission charging arrangement allows *transmission* businesses to levy a *modified load export charge* on *transmission* businesses in neighbouring *regions*. Transmission load customers would subsequently pay a share of the costs of *transmission* used to import electricity into their *region* from neighbouring *regions*.

2. Overview of the process

An overview of the process to calculate *MLEC* is shown in the diagram below.

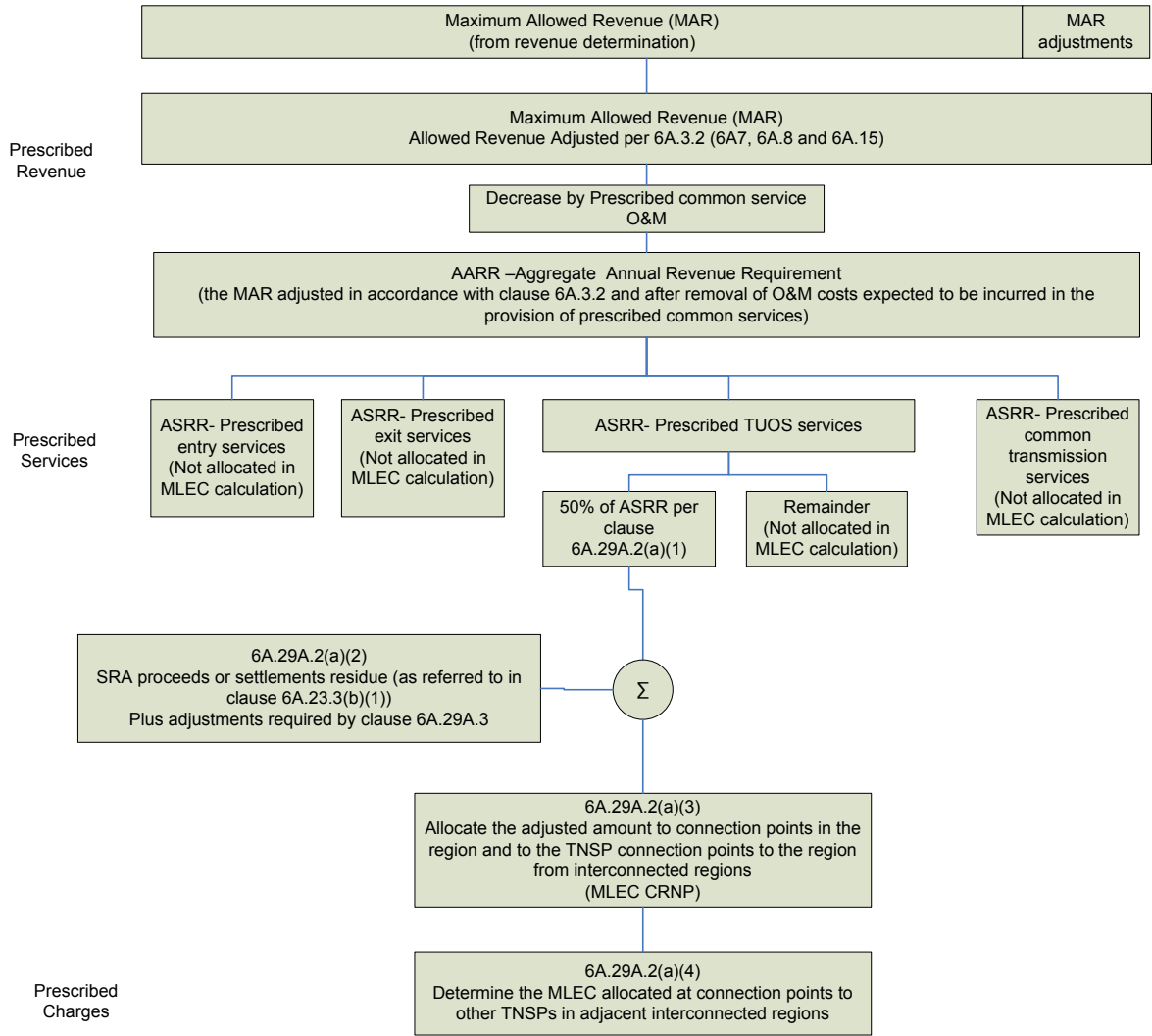

The steps involved to calculate *MLEC* are:

Step 1:

The *AARR* will be calculated as described in section 6.3 of ElectraNet’s proposed pricing methodology.

The allocation of the *AARR* to each of the *transmission* service categories will be calculated as described in section 6.6 to 6.8 of ElectraNet’s proposed pricing methodology. This will determine the *ASRR* to be recovered from *prescribed TUOS services*.

The calculations in Step 1 are the same as for calculating *transmission* prices.

Step 2:

As required by Clause 6A.29A.2(a)(1) of the Rules, the *modified load export charge* is to be calculated from 50% of the *ASRR* for *prescribed TUOS services*.

Step 3:

The amount determined in Step 2 is the *TUOS* revenue to be recovered on a locational basis and is adjusted in accordance with Clause 6A.29A.2(a)(2) of the Rules by:

- subtracting estimated inter-regional *settlements residue auction* proceeds;
- subtracting a portion of the *settlements residue* as referred to in clause 6A.23.3(b)(1);
- including any adjustments as required by 6A.29A.3.

Step 4:

Clause 6A.29A.2(a)(3) requires the adjusted amount from Step 3 to be allocated to *connection points* of *transmission customers* in the *region* and to *CNSPs* interconnected to the *region* as if they were connected as *transmission customers*. This allocation will be made on a proportionate use of *transmission system* assets.

Consistent with the requirements of clause 6A.29A.2(a)(3) the *MLEC CRNP* methodology for estimating the proportionate use of the relevant *transmission system* assets will be used.

The *MLEC CRNP* methodology is applied using the T-PRICE cost reflective network pricing software used by all TNSPs in the NEM.

The *CRNP* methodology requires three sets of input data:

- an electrical (load flow) model of the network;
- a cost model of the network; and
- a set of load/generation patterns.

Appendix C of this Pricing Methodology describes the *CRNP* methodology in more detail.

The network model differs slightly from the network model used for price determination as described in the proposed pricing methodology. The network model in the *MLEC CRNP* methodology does not require SRA proceeds to be converted into an equivalent asset as described in section 6.9.3 of the proposed pricing methodology.

The *MLEC CRNP* methodology does not require the utilisation adjustments characteristic of modified *CRNP*. The utilisation of system elements will be set to allocate 100% of system costs to loads when applying the *MLEC CRNP* methodology.

The key requirements for *MLEC CRNP* are:

- The modified load export charge to be determined using standard *CRNP* approach.
- All transmission elements are to be included.
- All half hour periods in the previous full financial year are to be used.
- Peak usage of assets must be used.

For each regulatory year the modified load export charge will be calculated using the *MLEC CRNP* approach. The calculation will use generation and load data from the previous financial year completed at the time the *MLEC CRNP* is being calculated.

Step 5:

Clause 6A.29A.2(a)(4) requires the modified load export charge to be recovered from Co-ordinating Network Service Providers in interconnected regions to be the amount allocated to connection points to neighbouring regions as determined in Step 4.

3. Timetable for the provision of data

As required by 6A.29A.4(e), each TNSP located in the region is required to provide the CNSP with all information reasonably required for the calculation of the *MLEC* estimate.

To facilitate this information transfer, the Section 2.6 of the AER guidelines require a CNSP to specify a timetable for the provision of all necessary data for the calculation of the inter-regional and intra-regional transmission charges.

The following timetable for the provision of data will facilitate the calculation of all modified load export charges to apply in the region by 15 March each year.

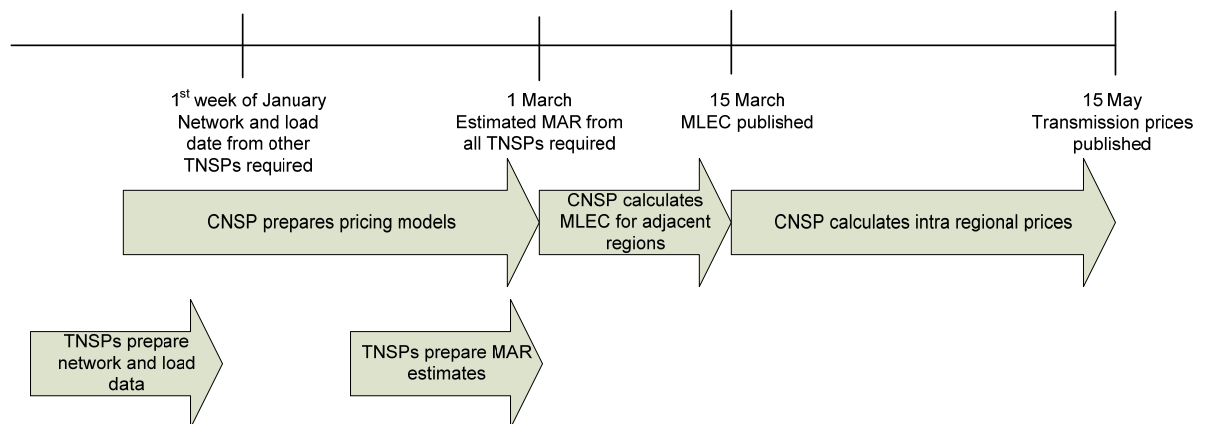

4. Billing the modified load export charge

ElectraNet will issue a monthly bill to the CNSP in each interconnected region for the *MLEC* amount payable to ElectraNet in accordance with Clause 6A.29A.4(a) of the Rules. The monthly bills will include any adjustments made to it in accordance with the Rules (Clause 6A.29A.3 of the Rules).

In accordance with Clause 6A.29A.4(b) of the Rules, the monthly bill will include:

- The total annual estimate of *MLEC* payable by the CNSP.
- Details of the *MLEC CRNP* allocation and the adjustments as specified in Clauses 6A.29A.3 and 6A.23.3(f)
- The monthly instalment amount

5. Billing arrangements between multiple TNSPs in a region

5.1 Allocation of amounts to each TNSPs in the same region

In accordance with clause 6A.29A.5(a) of the Rules, where there is more than one TNSP in a region, the CNSP is required to allocate any amounts receivable by or payable to it for MLEC to each TNSP in accordance with its pricing methodology.

As the appointed Co-ordinating Network Service Provider referred to in Clause 6A.29.1 of the Rules, ElectraNet will allocate any amounts receivable or payable for MLEC to each relevant Transmission Network Service Provider in the SA region for the following year as required by clause 6A.29A.5 of the Rules.

This allocation will be based on the MLEC CRNP methodology for estimating the proportionate use of the relevant transmission system assets. The allocation of amounts will be calculated according to intra-regional, rather than inter-regional, network utilisation.

For the avoidance of doubt, these amounts will be incorporated in the connection point prices determined by ElectraNet for each TNSP in the SA region. ElectraNet collects both ElectraNet's and MTC's regulated revenue entitlements via ElectraNet's prescribed transmission service prices.

As these prices incorporate the full impact of the MLEC no net amounts arise under clause 6A.29A.5(a) of the Rules.

5.2 Billing each TNSP in the same region

Clause 6A.29A.5(b) of the Rules requires the CNSP to issue bills for the net amounts (allocated in clause 6A.29A.5(a)) receivable by or payable to the CNSP for MLEC to each TNSP in its region.

As noted in section 6.2 as the appointed Co-ordinating Network Service Provider referred to in clause 6A.29.1 of the Rules ElectraNet collects both ElectraNet's and MTC's regulated revenue entitlements via ElectraNet's prescribed transmission service prices.

Notwithstanding these prices incorporating the full impact of the MLEC bills are required to be issued under clause 6A.29A.5(b) of the Rules.

ElectraNet will issue a bill to each TNSP in the SA region for the net amount of MLEC as required in clause 6A.29A.5(b) of the Rules to be paid in equal monthly instalments or as documented in revenue collection agreements negotiated between the parties. Such payments will be calculated by ElectraNet. ElectraNet will also provide reasonable details on the calculation of these amounts.

6. Worked example – modified load export charge

The worked example uses the same amounts referred to in the examples of the proposed pricing methodology.

Step 1 – Aggregate annual revenue requirement (AARR)

In accordance with Clause 6A.22.1 of the Rules, the maximum allowed revenue is adjusted:

- in accordance with clause 6A.3.2 of the Rules, and
- by subtracting the operating and maintenance costs expected to be incurred in the provision of prescribed common transmission services; and
- by any allocation as agreed between *Transmission network* Service Providers in accordance with clause 6A.29.3 of the Rules.

This example assumes that the maximum allowed revenue is \$2,604,434.

Table F.1 Derivation of AARR to be allocated to the four services

Derivation	Amount (\$)
Maximum allowed revenue	2,604,434
Total adjustments for:	
<ul style="list-style-type: none"> • network support pass through; • cost pass through; • payments or penalties under the service target performance incentive scheme; and • contingent projects. 	-45,000
Deduct operating and maintenance expenditure (incurred in the provision of prescribed common services)	-55,000
AARR to be allocated	2,504,434

Step 2 – Annual service revenue requirement

Similar to the calculation example in section 6.2 of the proposed pricing methodology, the *ASRR* for each category of service is calculated as shown in Table A1.2.

Table F.2 Asset allocations to service categories

Category	Asset Value (\$)	Cost Share
Exit service	6,972,222	16.2%
Entry service	1,761,111	4.1%
TUOS service	33,566,667	78.0%
Common service	750,000	1.7%
Total	43,050,000	100.0%

The cost share percentages shown in Table A1.2 are used to allocate the revenue to be recovered from each service category. In accordance with the adjustments set out in Table A1.1, Table A1.3 shows that the revenue to be allocated (the *AARR*) is \$2,504,434.

Table F.3 Calculation of *Annual Service Revenue Requirements (ASRR)*

Category	Cost Share	Revenue (AARR) to be recovered from each service (\$)
Exit service	16.2%	405,609
Entry service	4.1%	102,453
TUOS service	78.0%	1,952,741
Common service	1.7%	43,631
Total	100.0%	2,504,434

Clause 6A.29A.2(a)(1) then requires 50% of the ASRR for prescribed TUOS services to be calculated.

Category	Asset Value (\$)
50% of TUOS service	976,371

Step 3 – Adjustment for settlement residue auction proceeds

For this example the SRA proceeds and other adjustments are assumed to be zero.

Step 4 – Standard MLEC CRNP Calculation

An electrical model of the South Australian *transmission network* is set up including all transmission elements. The TPRICE software is used to calculate the allocation of costs based on a proportionate use of *Transmission System* assets.

The total allocation to each connection point to another region is then determined.

Table F.5 Standard CRNP allocation and I/C cost share

Connection Point	CRNP ORC Allocation (\$k)	Cost Share
Region 1 – Connection Point 1	1,000	3%
Region 1 – Connection Point 2	300	1%
Region 1 – Connection Point 3	500	1%
Region 2 – Connection Point 1	600	2%
Region 2 – Connection Point 2	400	1%
Total for I/C connection points	2,800	8%
Total for all connection points	33,566,667	

Step 5 – Modified load export charge to be recovered

The revenue to be recovered is pro-rated using the adjusted *AARR* from Step 2.

Table F.6 Modified load export charge

Connection Point	Cost Share	Revenue to be recovered from each connection point (\$)
Region 1 – Connection Point 1	3%	29,087
Region 1 – Connection Point 2	1%	8,726
Region 1 – Connection Point 3	1%	14,543
Modified load export charge for Region 1		52,356
Region 2 – Connection Point 1	2%	17,452
Region 2 – Connection Point 2	1%	11,635
Modified load export charge for Region 2		29,089