

Dalrymple ESCRI-SA Battery Energy Storage Project

SEPA Energy Storage Working Group

1 April 2020

Hugo Klingenberg
Manager Network Development
ElectraNet

John Glassmire
Senior Advisor

ABB Power Grids Grid Edge Solutions

In partnership with:



ARENA
Australian Government
Australian Renewable
Energy Agency



Advisian
WorleyParsons Group

This activity received funding from ARENA as part of ARENA's Advancing Renewables Programme

Outline

- South Australian power system overview
- Dalrymple ESCRI-SA Battery Energy Storage System (BESS)
 - Overview & business case
 - Technical details of the ABB solution at Dalrymple
 - Operational experience
- Replicating the success of the Dalrymple BESS

Where is South Australia? ... and who is ElectraNet?



Power System Overview & Context

South Australia (SA) is at the forefront of energy transformation

- Abundant high quality renewable energy resources with leading wind and solar penetration levels compared to demand
- Last coal fired power station closed 2016
- Reliance on gas generation and impact of higher gas prices
- SA system black and load shedding events have led to heightened concerns about power system security
- Emerging concern of distributed solar PV 'shake-off' for nearby generator unit faults
- ElectraNet is the Transmission Network Service Provider in SA
- Sparsely populated State – 1.7M people with 1.3M in Adelaide
- 3,100 MW maximum demand
- 5,600 km of transmission lines & 96 substations and switchyards

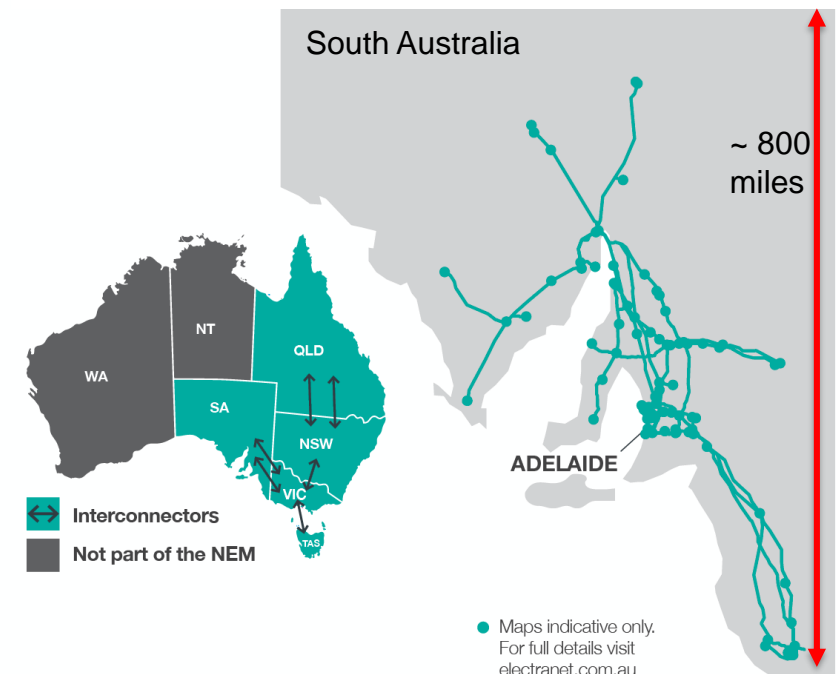

NEM – National Electricity Market
AEMO – Australian Energy Market Operator

Changing Generation Mix

South Australia faces the prospect of zero (or even negative) grid demand at times

- The challenges seen in SA in relation to minimum levels of synchronous generation are a first in any large scale power system in the world...
- Current wind/ solar generation capacity is...
 - About 170% of average demand
 - > 500% of minimum demand

Grid connected intermittent generation capacity relative to demand (MW)

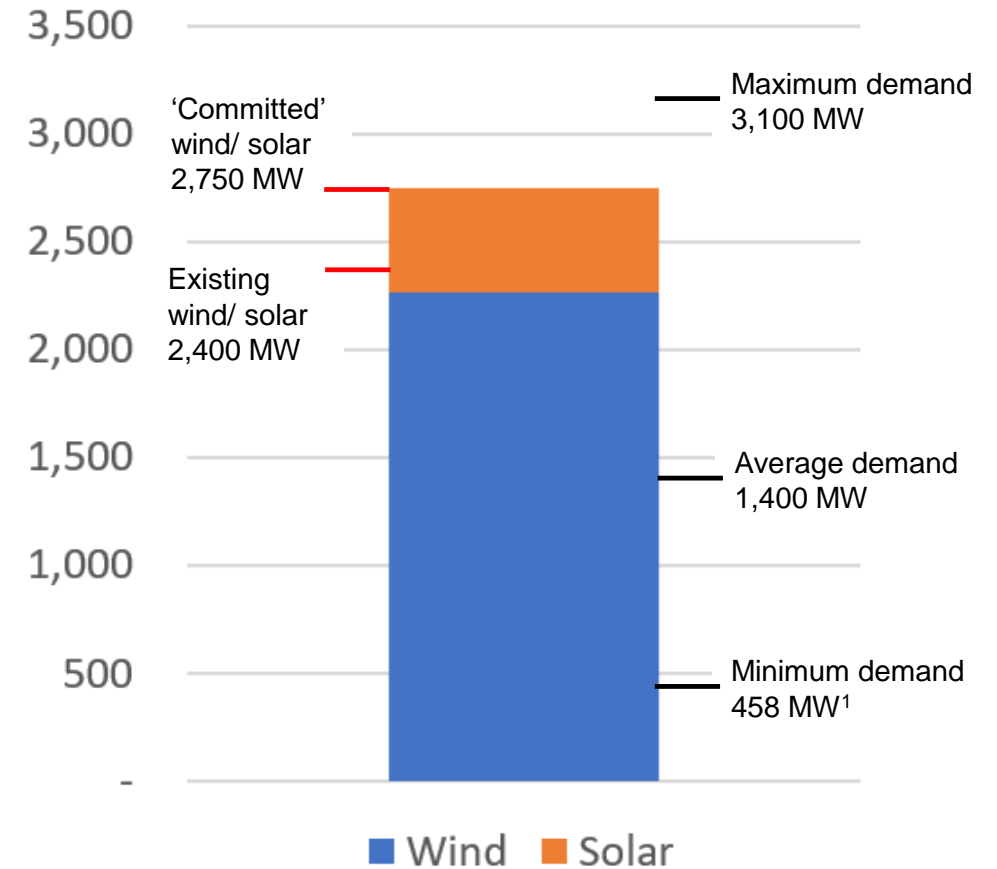

1. Minimum demand includes contribution from embedded, distributed solar PV

Source: AEMO, Energy Live, 11 November 2019

Minimum demand in South Australia decreasing

Record low SA electricity demand of 458 MW set on Sunday, 10 Nov 2019

Source: AEMO, Energy Live, 11 November 2019

- Minimum demand has been decreasing between 70-90 MW per annum in recent years
- Distributed solar PV is decreasing minimum demand
 - Current contribution at minimum demand times is about 800 MW
 - This generation is non-scheduled (not controllable) and still growing strong

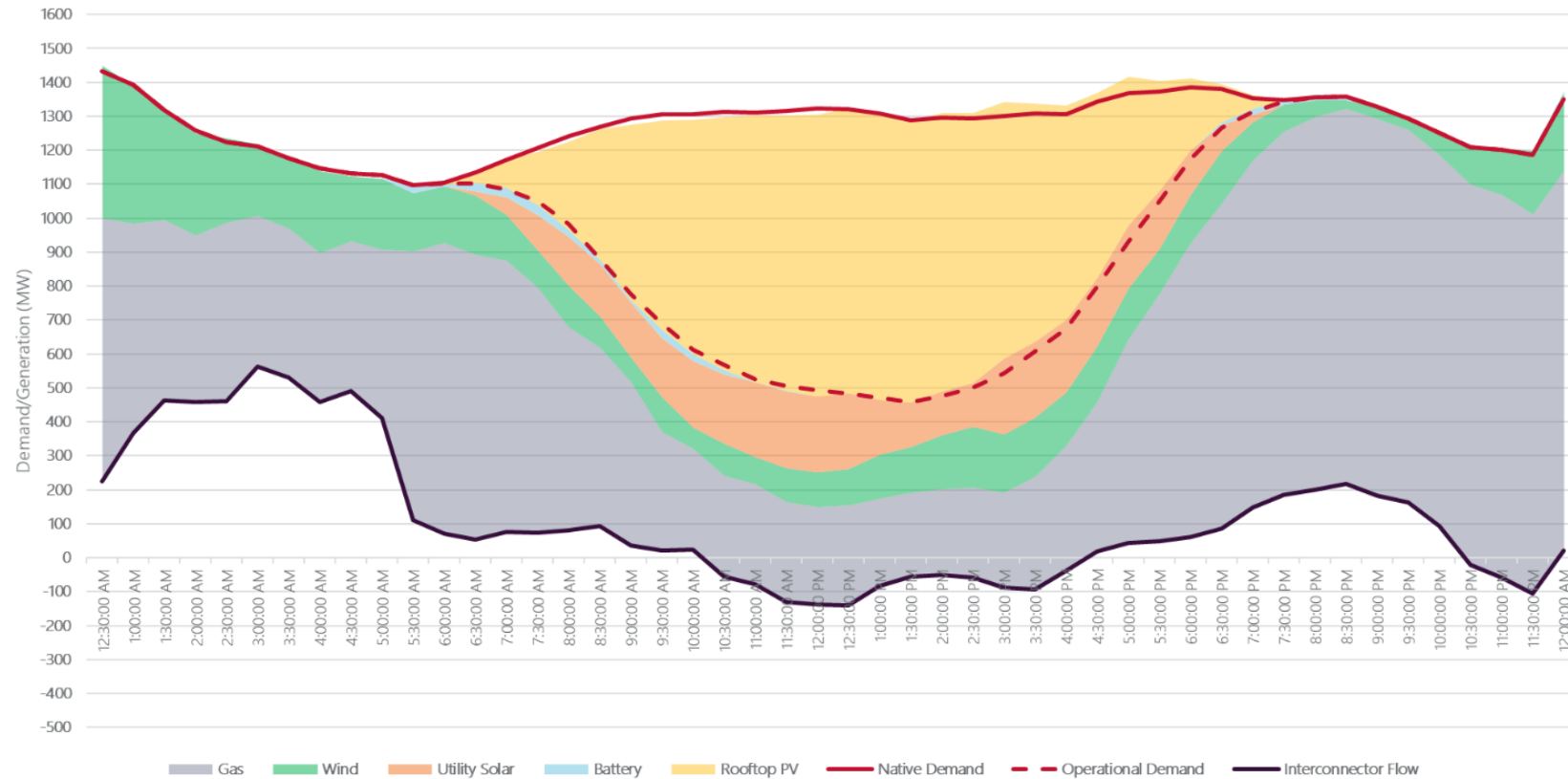

Dalrymple ESCRI-SA BESS Business Case & Commercial Arrangements

Innovation Awards

Energy Networks Australia:
2019 Industry Innovation Award

South Australia Premier's Award:
2019 Energy Sector -
Transformational Innovation



Winner

Energy Sector

Innovation – Transformational Innovation

Presented to

ElectraNet

Dalrymple Battery Energy Storage System

Hon Steven Marshall MP
Premier of South Australia



Project scope and objectives

Scope: Nominal 30 MW, 8 MWh lithium-ion battery

1. Gain practical experience and learnings from the application of grid connected utility scale battery storage as an enabler of large scale intermittent renewable energy on an interconnected system
2. Demonstrate that utility scale battery storage can effectively provide network reliability and security services alongside market services
3. Demonstrate network ownership of battery storage and commercial appropriate separation of provision of regulated services and competitive energy market services
4. Demonstrate “seamless” islanded operation with 100% renewable generation following transmission outages

Location

Site selected to maximise value from battery

- Connection at 33 kV at Dalrymple substation on Yorke Peninsula – land available
- Opportunity to reduce expected unserved energy under islanding conditions (max demand is about 8 MW but on average need about 3 MW for 2 hours)
- Site is close to the 91 MW Wattle Point Wind Farm – provides opportunity for battery to support islanded operation with the wind farm and 2 MW of local rooftop solar, following network outages

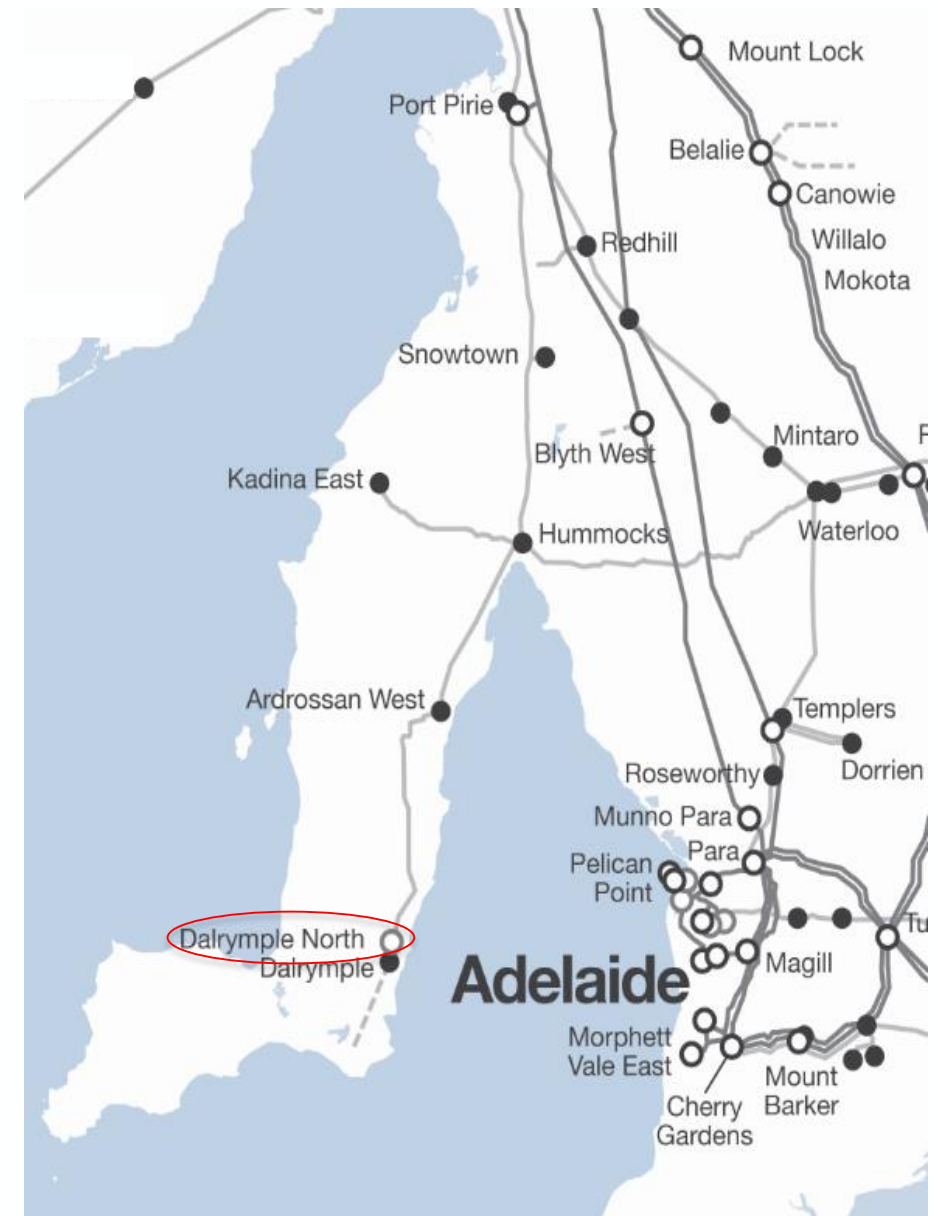

Benefits / Revenue streams

Providing both regulated and competitive market services

Regulated services ¹ (ElectraNet)	Competitive market services (AGL Energy)
Fast frequency response Heywood Interconnector benefit	Ancillary services revenue (FCAS)
Reduced unserved energy benefit	Energy trading

1. During project implementation the BESS was incorporated in the System Integrity Protection Scheme (SIPS), providing additional regulated benefits. The SIPS is an important emergency control scheme that significantly enhances power system security in South Australia (SA) for the non-credible loss of multiple generators in SA.

Commercial arrangements

Providing both regulated and competitive market services

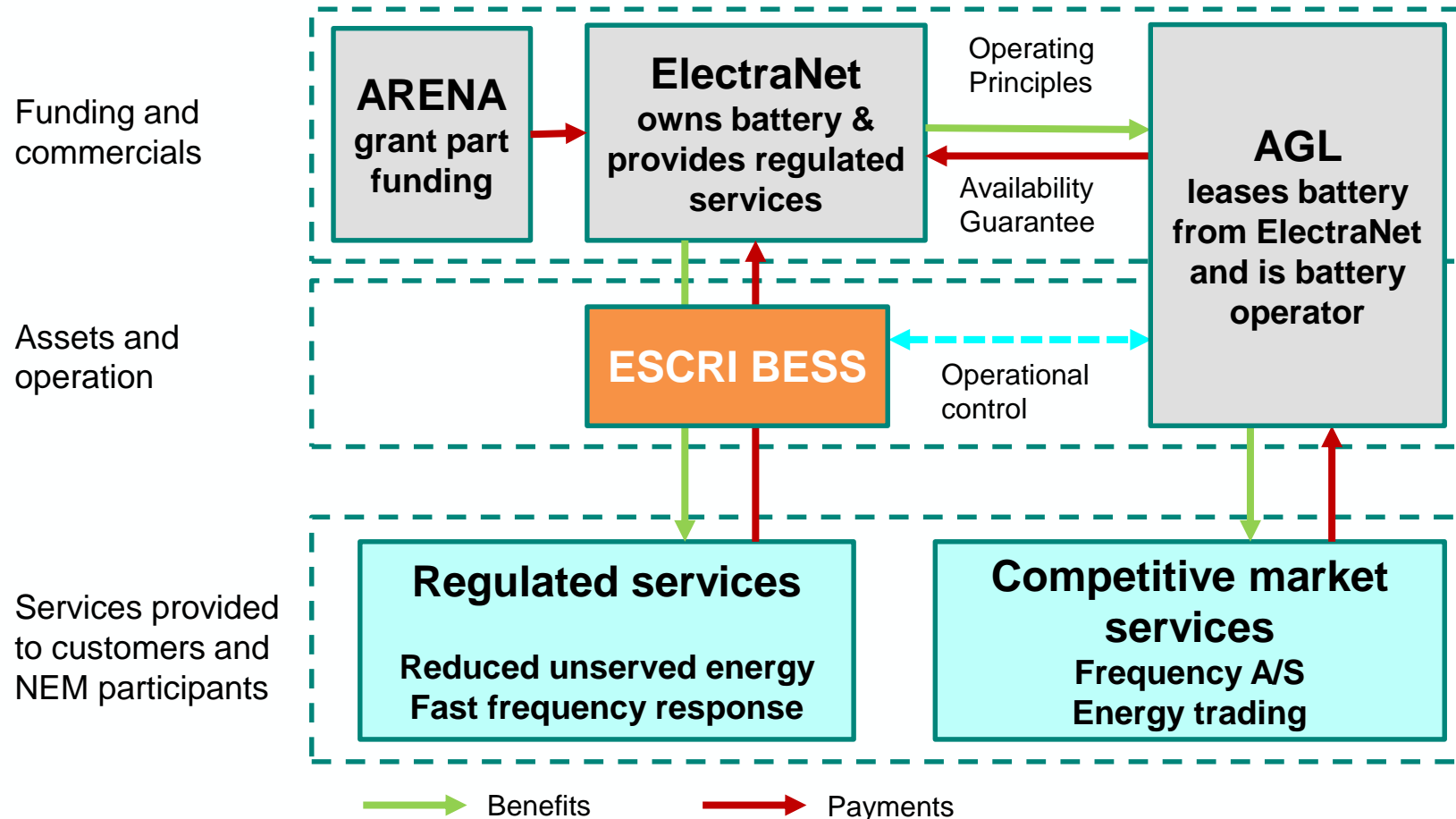

EPC/ D&C contract and 12-year maintenance agreement awarded to Consolidated Power Projects (CPP) following extensive procurement process

Key Metrics – First 12 months of operation

Key Performance Metric	Value for Reporting Period (14-12-2018 to 14-06-2019)	Value for reporting period (14-06-2019 to 14-12-2019)
Average BESS Availability	98.01%	97.35%
BESS Charging Cost	AUD 120,000	AUD 101,000
BESS Discharge Revenue	AUD 116,000	AUD 97,000
FCAS Revenue	AUD 1.33m	AUD 3.73m

Technical details of the ABB solution at Dalrymple



The benefits of PowerStore

Showcasing the benefits of robust and flexible BESS with smart controls and automation



ABB PowerStore technology

Grid-following and grid-forming converters → Virtual Synchronous Machine

Grid Following, typically CSI

Current Source Inverter (CSI)

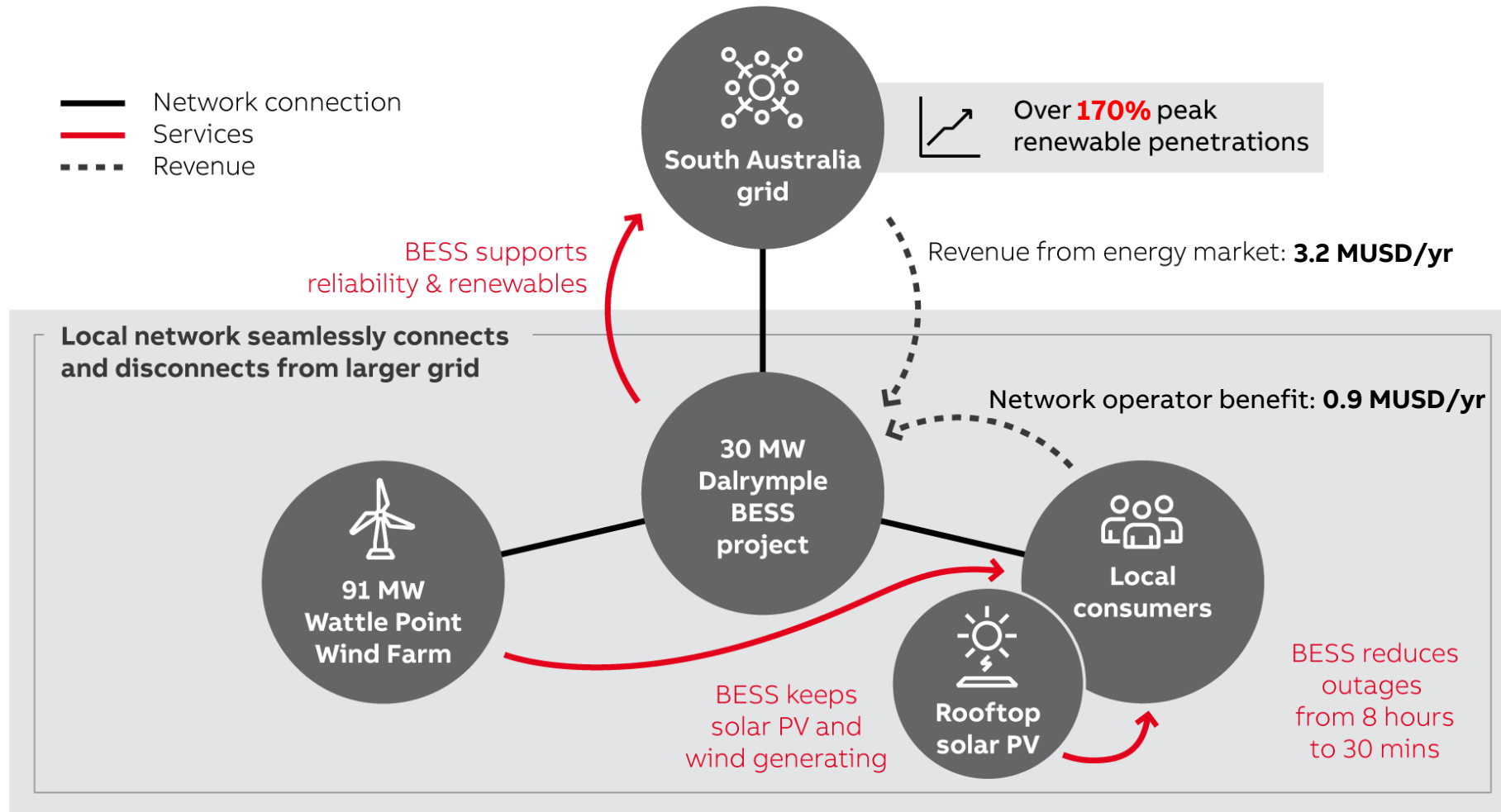
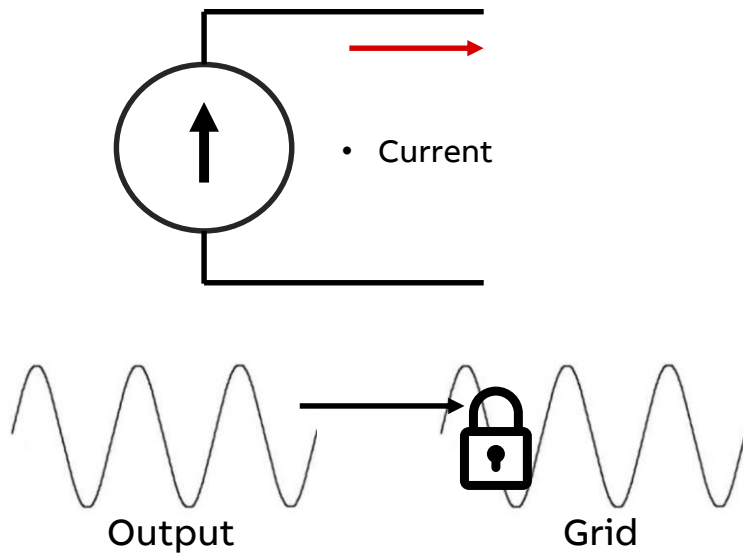

Grid Forming, typically VSI

Voltage Source Inverter (VSI)

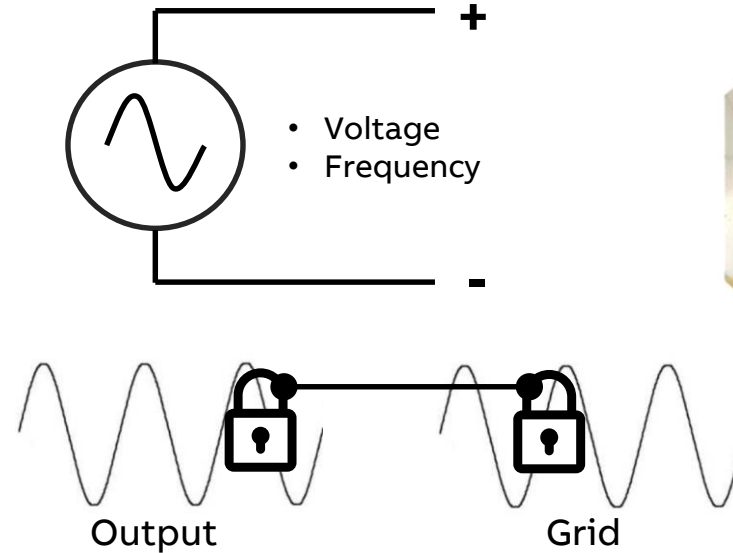

Virtual Synchronous Machine (VSM)

ABB PowerStore

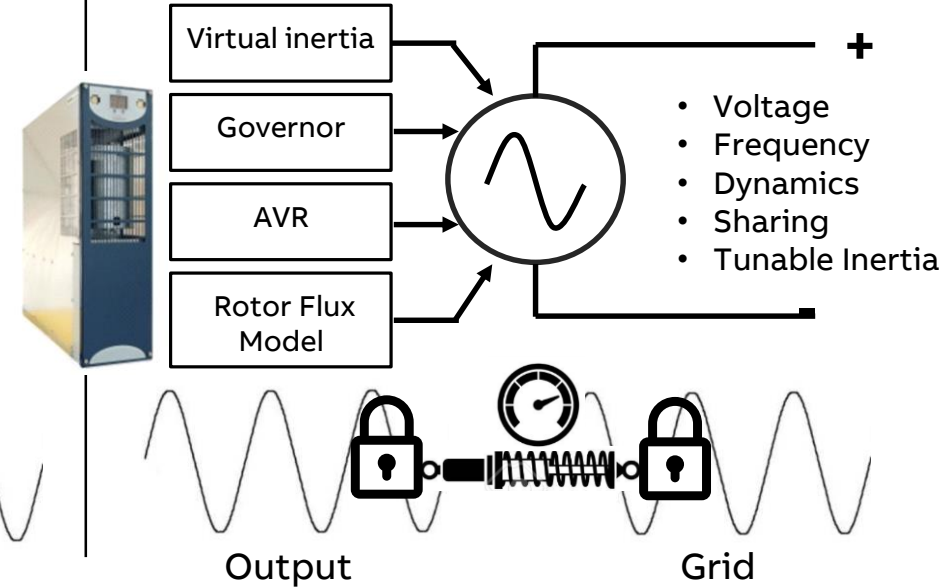

The key to stabilizing grids and unlocking new revenue streams is digital automation and smart controls intelligently applied to high power grid-forming converter(s)

Key services PowerStore provides to stabilize the grid

Leveraging ABB's proprietary Virtual Generator Mode (VGM) as a Virtual Synchronous Machine

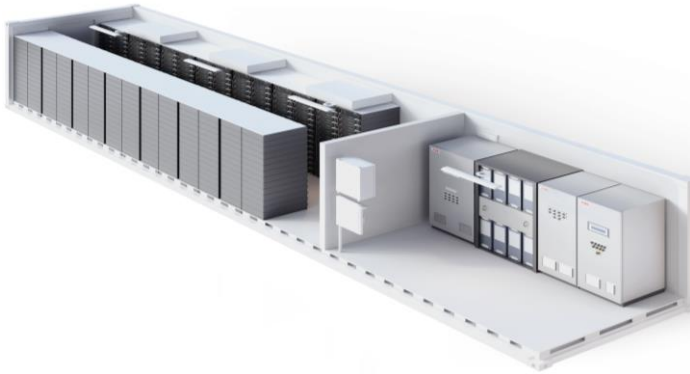

Fault current injection

- provides a more stable alternative
- clears faults in the network
- limits network oscillations from phase locked loop (PLL) issues common with existing inverter based resources

Seamless islanding

- grid-forming inverter with proprietary controls
- increases local network reliability
- Operate entirely on renewable sources (wind and solar)
- 100+ km of lines with 91MW wind farm and >2MW of distributed solar PV

Fast power injection

- Fast response (< than 250 msec) for an external command
- Instantaneous response to events sensed locally
- Voltage and frequency support

Virtual inertia

- stabilises and strengthens the grid
- mitigates impact of rate of change of frequency (RoCoF) events
- effective during both normal operation and disturbances

Black start

- PowerStore is an energization source that allows DER to couple and restart power supply after an outage event
- After local network black start, can serve as black start resource for broader network

ABB e-mesh™ portfolio

Integrated control architecture for GES, from microgrids to utility-scale BESS

e-mesh™ Applications

SaaS applications to improve performance



- Forecast production and optimal planning
- Improve productivity and economical gains
- Business KPI dashboards and reports

e-mesh™ Monitor

Cloud-enabled remote monitoring and controlling of DERs

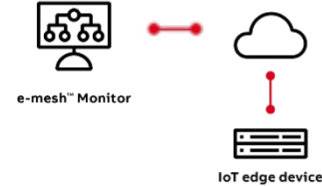

- Monitoring and control
- Bidirectional data flow from (and) or to the field
- Access from anywhere anytime

e-mesh™ SCADA

Distributed energy resources automation solution

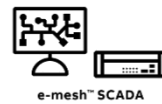

- Data acquisition from DER's and substations
- Supports international and local communication protocols
- Interaction with TSO/DSO

e-mesh™ Control

Intelligent and efficient power management

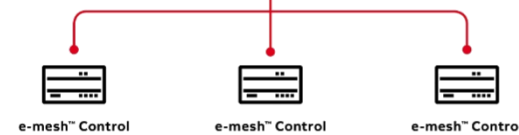

- Renewable power generation grid code compliance
- Network voltage control
- Feeder & Load demand management

e-mesh™ PowerStore™

Smart battery energy storage solution

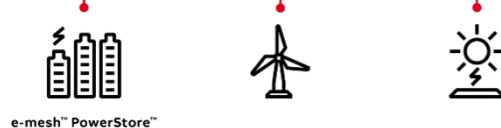

- Supports various applications such as islanding, seamless transition, black start, spinning reserve and more

Integration at ElectraNet's Dalrymple substation



Wattle Point Wind Farm
91 MW
(55 x Vestas V82 directly coupled induction generators)

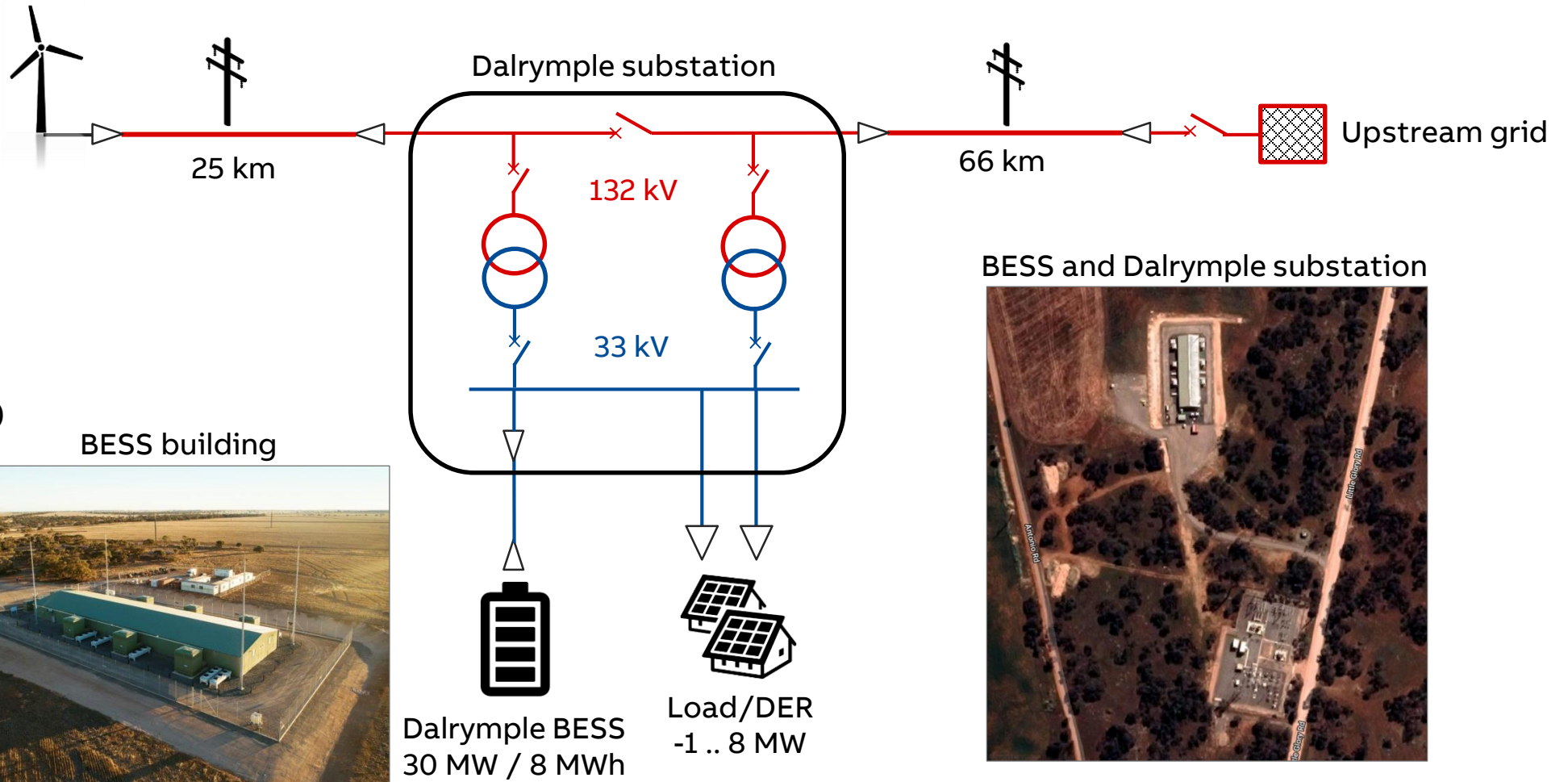

BESS and Dalrymple substation



Operational Performance

- Local islanding
- Other system events

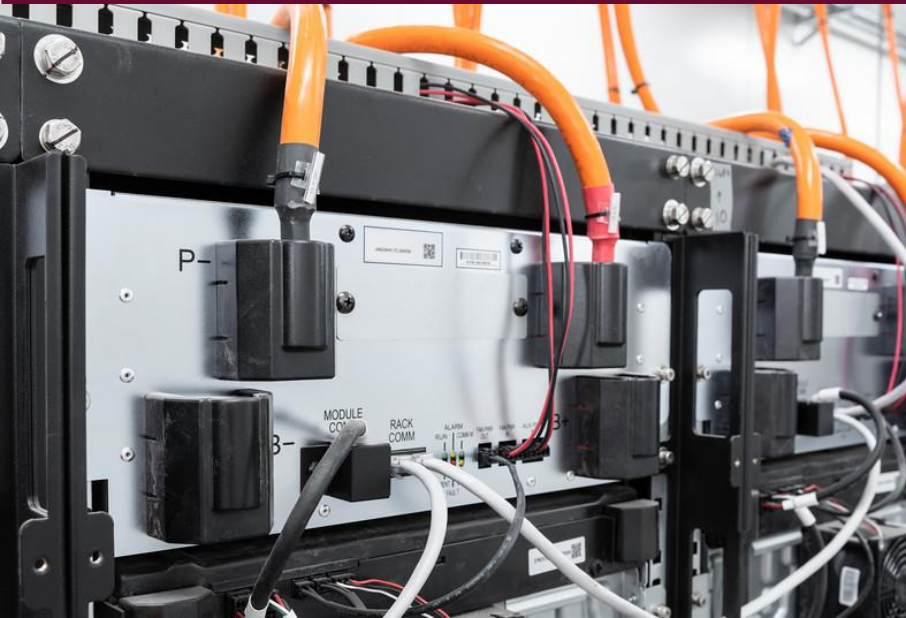

System Events – First 12 months

- 14 operational system events:
 - Eleven of these events were single-line trips or a frequency event
 - The other three events were more significant and led to the BESS supplying load to prevent or reduce the duration of an unserved energy event
- High-speed data recordings from Power System Performance Monitor (PSPM) confirmed the BESS successfully rode through the fault or responded as required

Largest automated BESS operating a microgrid



Industry innovation

A number of firsts

- Largest (30 MW BESS) indoor and climate-controlled BESS installation in Australia
- Largest autonomous regional microgrid development to-date. All-in-one control design co-optimised for both grid-connected and islanded operation, allowing seamless transition between the two operating modes
- Grid-forming capability implies ability to operate conceptually at very low Short Circuit Ratios ($\ll 1.5$)
- Islanded grid master control including WF generation MW dispatch / curtailment
- Black-start capability for 8 MW island
- Topology-based Islanding Detection Scheme (IDS)

Planned islanding

- September 2018
 - BESS Active power
 - Wind farm
 - Seamless island for distribution customers

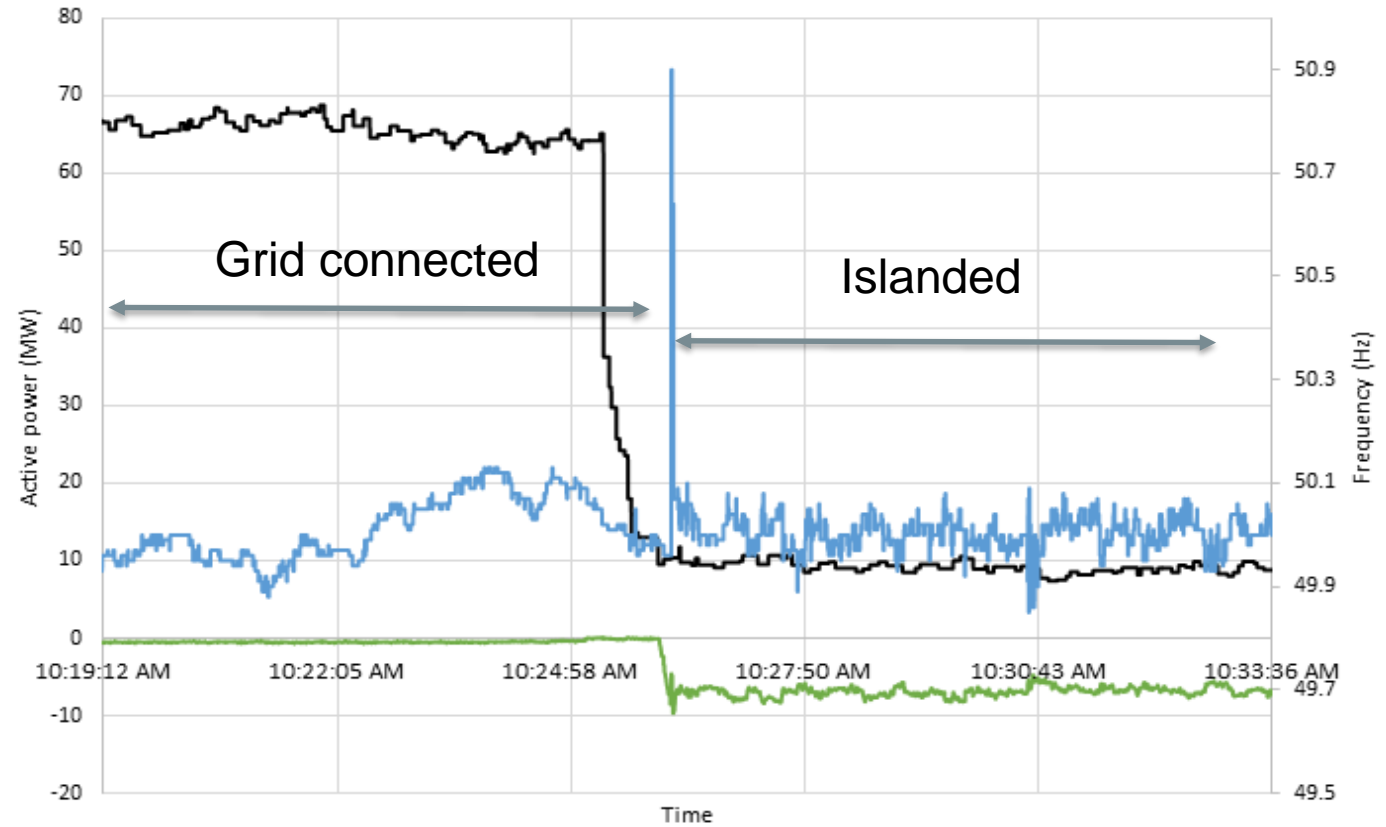

— BESS (MW) — Wind farm (MW) — Frequency (Hz)

Frequency went up to 50.8 Hz for short amount of time

Unplanned islanding

- March 2019
 - BESS Active (P) and Reactive (Q) load
 - Seamless island for distribution customers

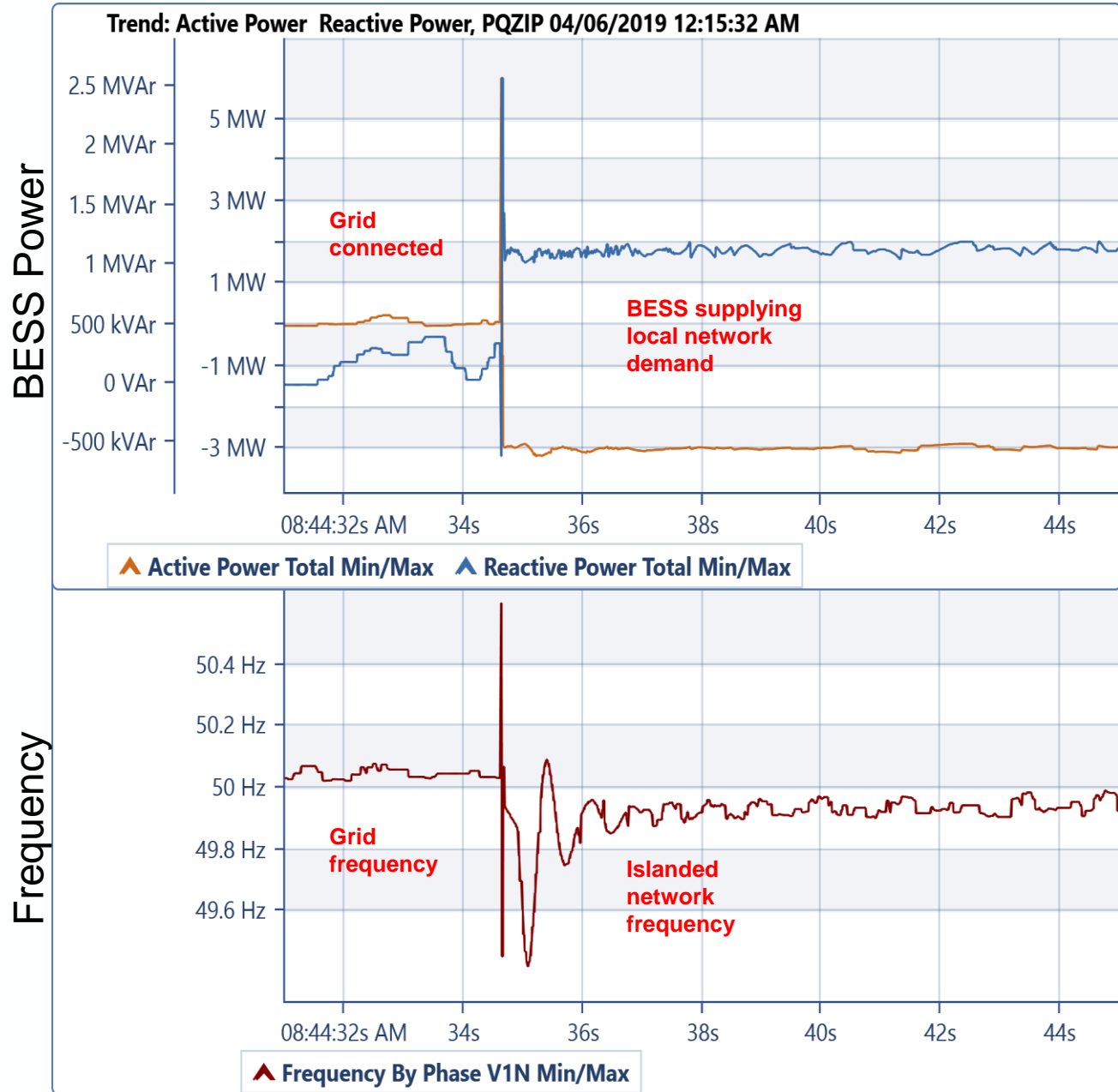

Fault ride through capability

- On 6 October 2019 at 03:35, a single phase to ground fault occurred on the Hummocks – Waterloo 132 kV line. The fault was cleared and the line successfully reclosed. High speed data recorded at the Dalrymple 33kV bus indicated the Dalrymple BESS successfully rode through the fault as shown below.

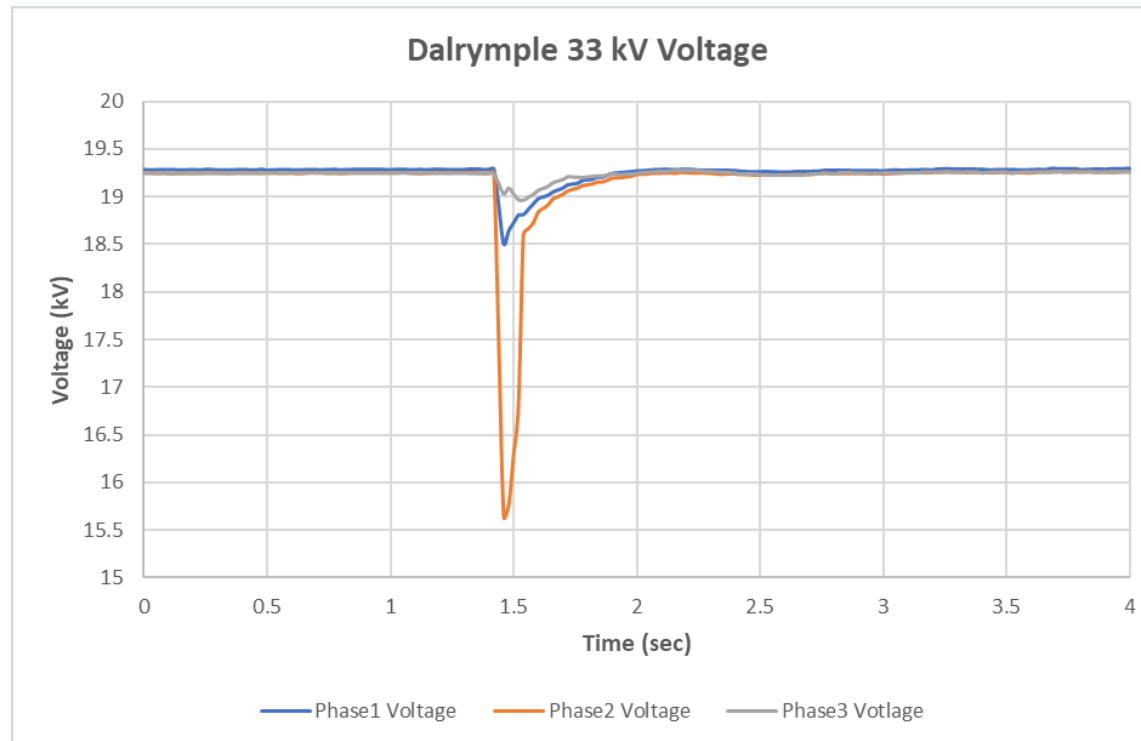

Hummocks – Waterloo 132 kV line fault on 6 October 2019

DBESS Active Power

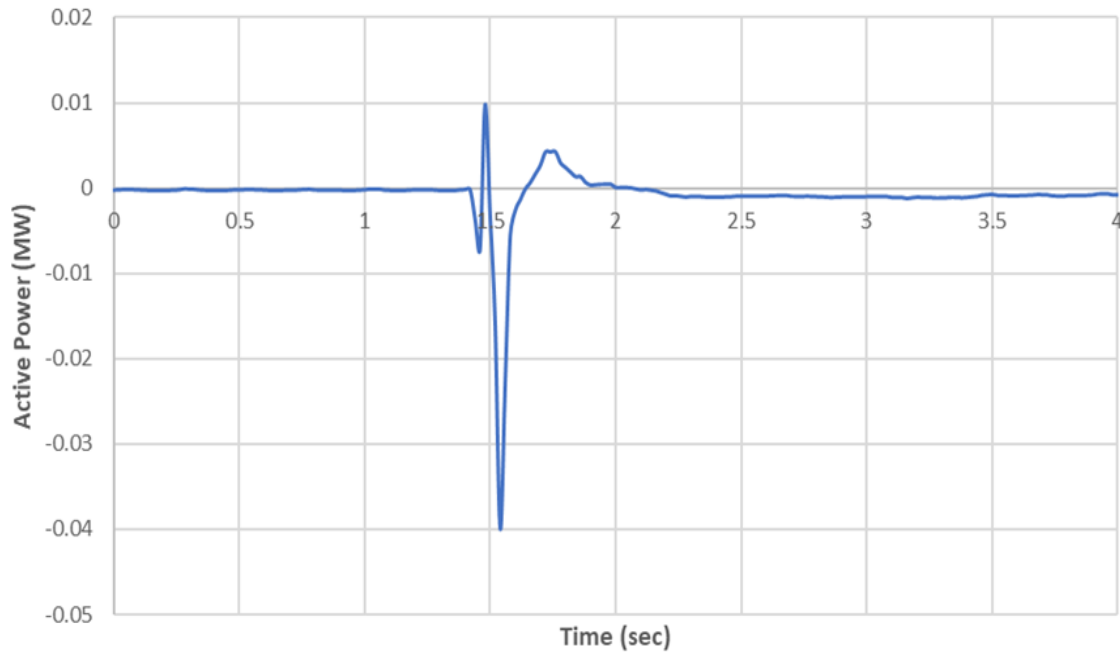

DBESS Reactive Power

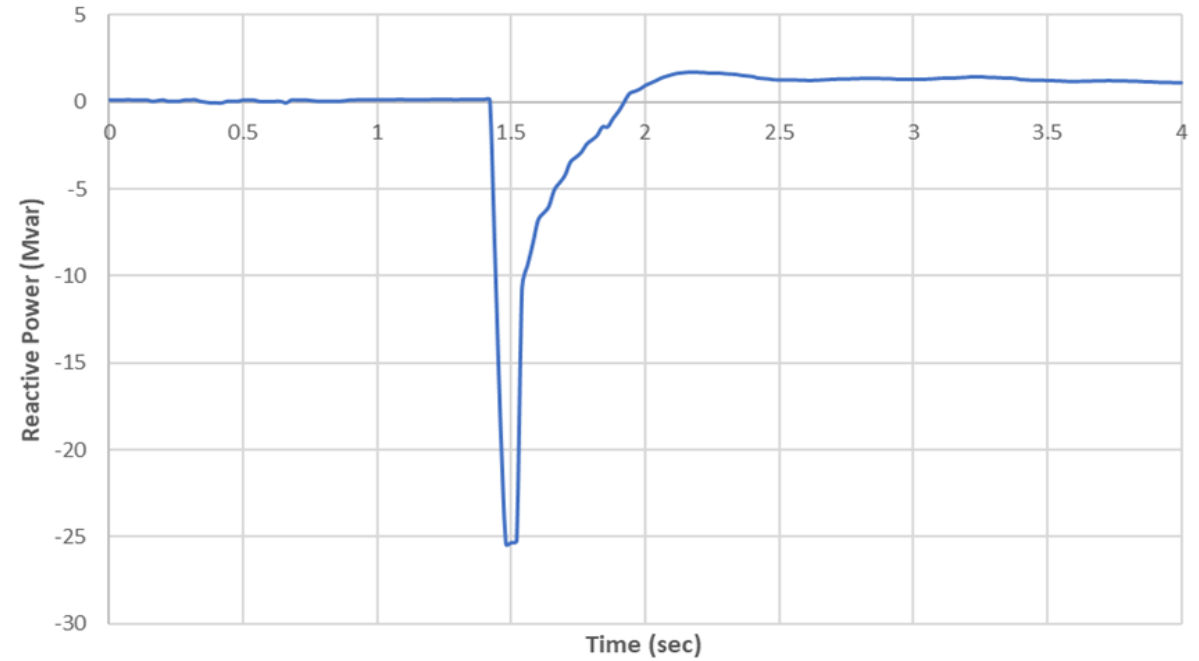

Bad event for the network, perfect event to demonstrate BESS

Heywood interconnector trip

- On 16 November 2019 at 18:06, the 500 kV double circuits between Heywood and Moorabool were tripped as the result of a fault.
- The Heywood interconnection between South Australia (SA) and Victoria was lost and the SA transmission network transitioned to an islanded condition.



SA Islanding from NEM

Heywood interconnector trip

- SA exporting approximately 300 MW at the time of the event.
- High speed data recorded at the Dalrymple 33kV bus indicated the Dalrymple BESS responded as shown

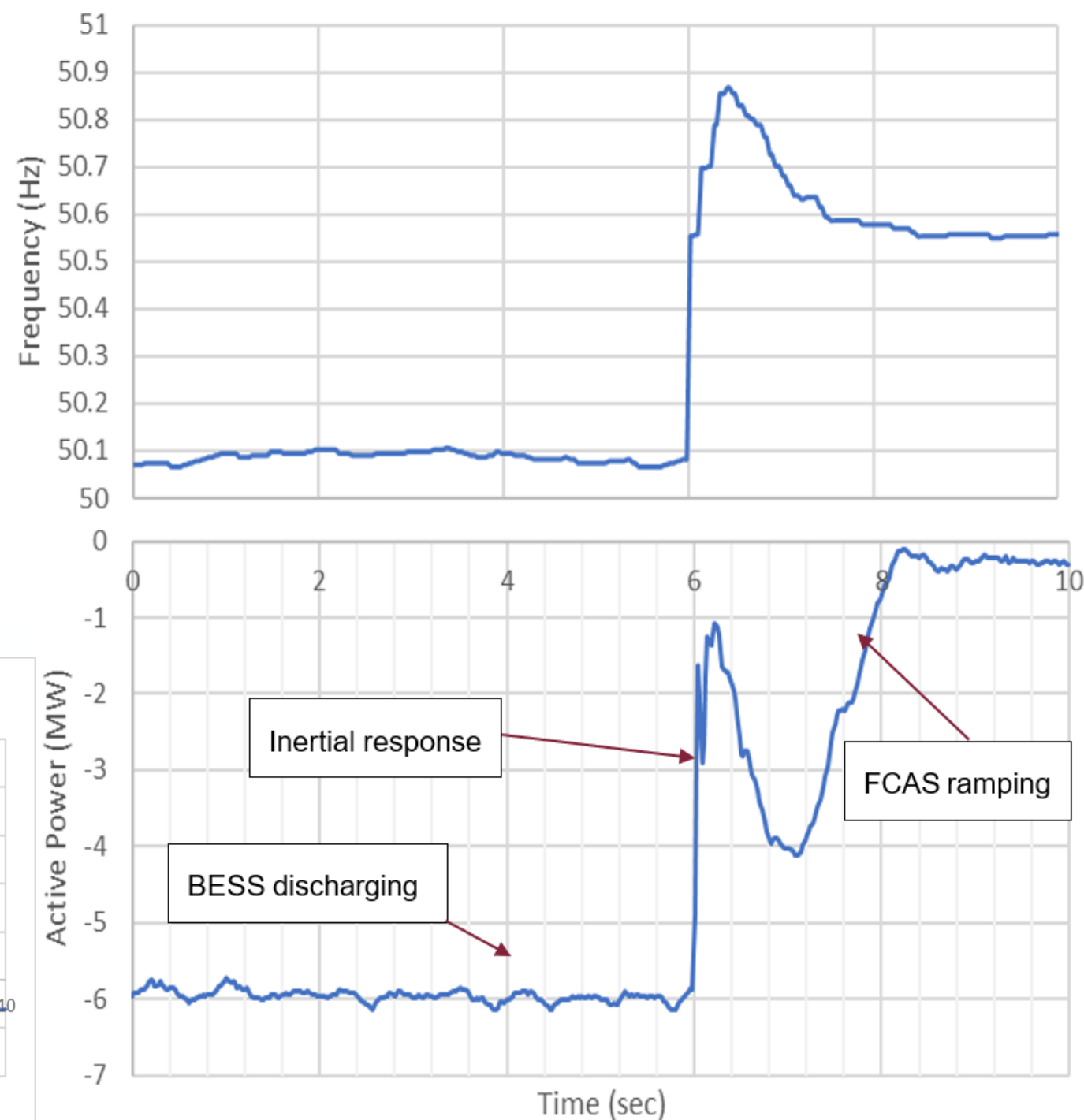
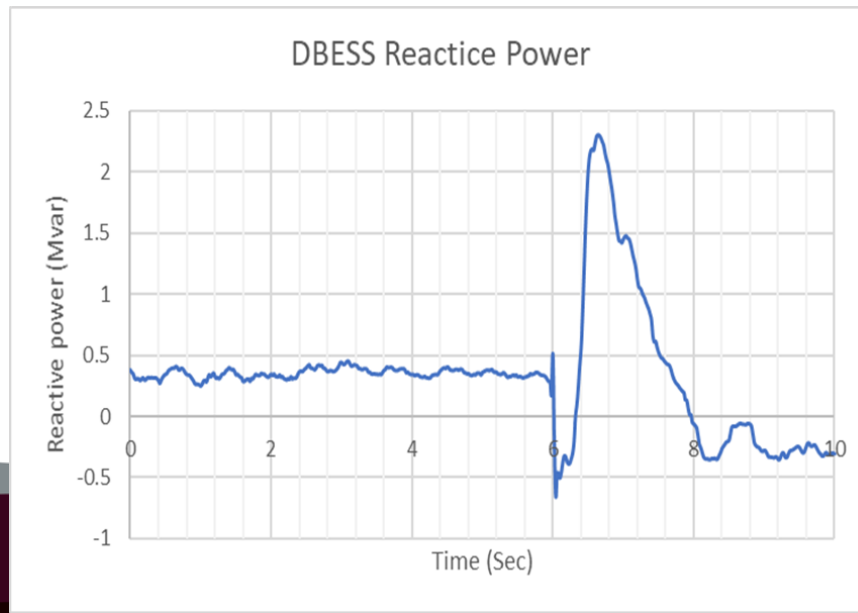

Replicating the success of the Dalrymple BESS

Replicating the success of the Dalrymple BESS

Unlocking the “value stack” for electricity networks

Unlock new revenue

Bring in revenue from energy and ancillary service markets, while also capturing value from a stabilized grid

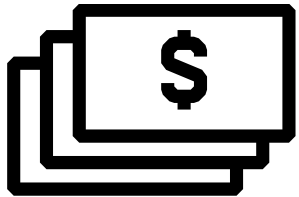

Stabilize your grid

ABB’s proprietary VGM implementation of a Virtual Synchronize Machine stabilizes the local network

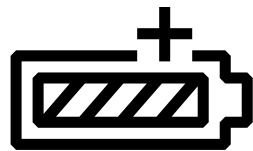

Reduce RE curtailment

Seamless islanding, coupled with voltage, reactive power, and frequency support maximizes renewables

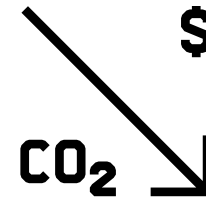

Provide continuous power

In the Dalrymple BESS project, PowerStore reduced customer outages by 93% -- from 8 hours to 30 minutes.

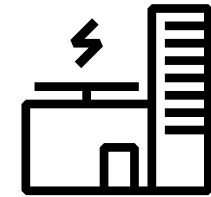

Smart controls and digital automation, paired with the PowerStore grid-forming BESS creates new opportunities

ABB Power Grids Grid Edge Solutions

Global microgrid and battery energy storage system solutions pioneer and partner

Leading global expertise

- 25+** 25+ years experience
- 200+** 200+ executed projects
- 500+** 500+ MW installed

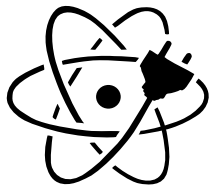

Innovation, technology & productization leadership



Global sales & service network

Broad portfolio of products & services

AND

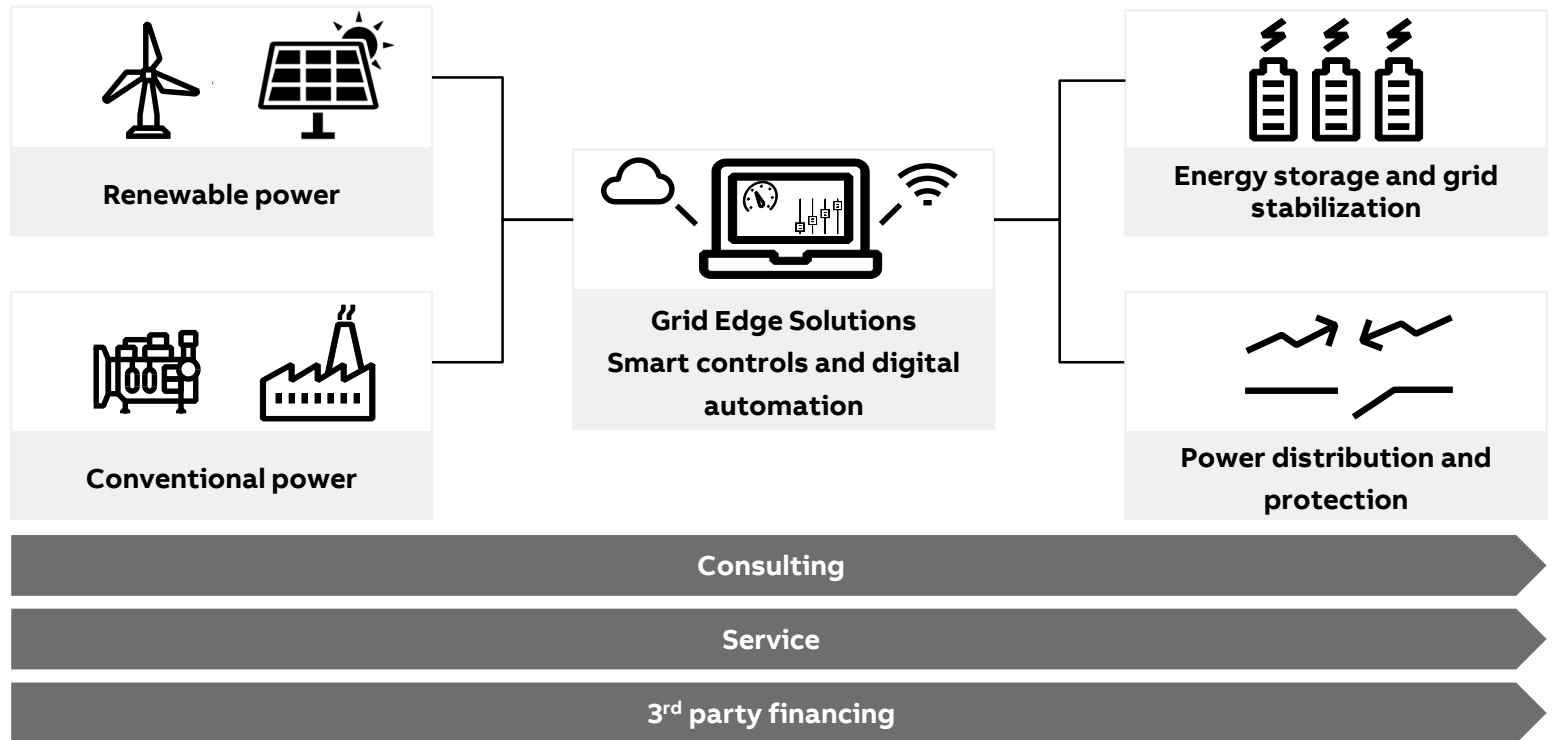

Conclusion



Knowledge Sharing Portal

- ARENA knowledge sharing commitments
 - Project delivering substantial knowledge sharing benefits to stakeholders
- Real-time data
- Data downloads
- Reports
- Presentations
- Knowledge Sharing Reference Group
 - Agendas
 - Minutes

www.escri-sa.com.au



Key learnings / challenges

- Each battery project appears to have its own set of unique challenges and some learnings are quite project specific
- Learnings/ challenges have included...
 - demonstration project with an aggressive timeline - pushing technical boundaries, e.g. wind farm islanding, vector shift
 - regulatory treatment
 - obtaining equipment models and evaluation of Generator Performance Standards (GPS)
 - clarifying AEMO registration and metering requirements
 - improving understanding of performance parameters - obtaining / refining equipment models for evaluation of Generator Performance Standards, exacerbated by optimising control for grid-connected and islanded operation
 - islanding challenges
 - managing commercial contract signed before design was completed

Thank You

For more information contact:

Hugo Klingenberg
Manager Network Development

ElectraNet

klingenberg.hugo@electranet.com.au

John Glassmire
Senior Advisor

**ABB Power Grids Grid Edge
Solutions**

john.glassmire@us.abb.com



Additional slides



Energy trading, Synthetic Inertia, FCAS, Frequency Response



ABB continues to pioneer the frontier of BESS

Fairbanks BESS: in operation for more 17 years

About the Project

- **Project name:** Fairbanks, Alaska
- **Location:** USA
- **Completion date:** 2003

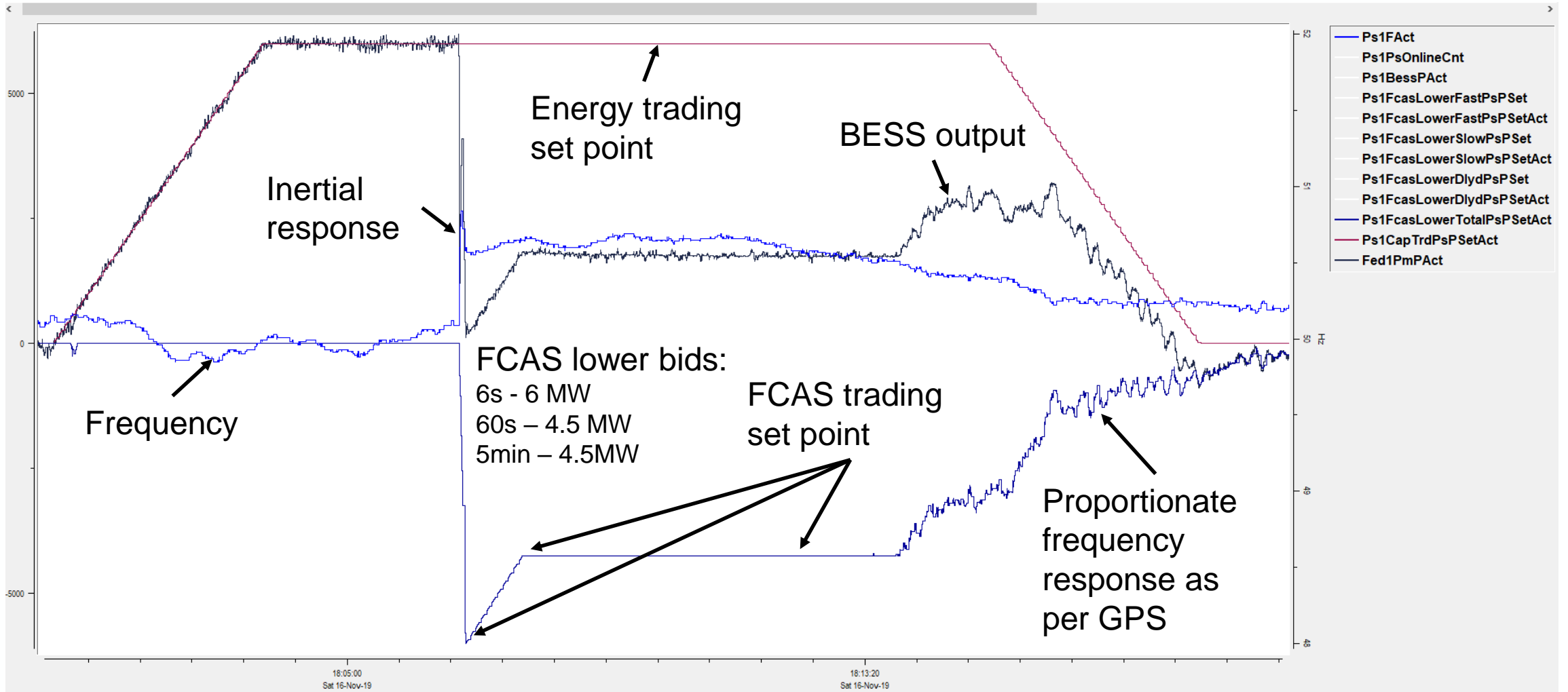
Solution

ABB's scope includes:

- Turnkey BESS including converter, transformer, Ni-Cd batteries (battery supplier SAFT), metering, protection and control devices and service equipment
- 27 MW - 15 minutes / 46 MW - 5 minutes
- BESS operation at temperatures as low as -52°C

Customer Benefits

- Improve reliability of electricity services
- Emergency power source to feed energy to the grid until backup generation can come online
- 15 minutes power boost to get generators online, leading to 90 percent reduction of power blackouts due to grid faults
- Cost-effective and reduced carbon emission solution



World's oldest BESS in service and also has held 2 world records in the BESS market