



Revised Proposed Pricing Methodology

1 July 2008 to 30 June 2013

3 April 2008

Version 1.0



ElectraNet Corporate Headquarters

52-55 East Terrace, Adelaide, South Australia 5000 • PO Box, 7096, Hutt Street Post Office, Adelaide, South Australia 5000
Tel: (08) 8404 7966 • Fax: (08) 8404 7104 • Toll Free: 1800 243 853

ElectraNet Revised Proposed Pricing Methodology – 3 April 2008

ElectraNet Pty Ltd (ElectraNet) is the principal electricity transmission network service provider (TNSP) in South Australia.

At ElectraNet we:

- Recognise that a strong and reliable electricity transmission system is important to the economy and future security of supply
- Consult with stakeholders and take their views into consideration
- Respond appropriately to our customers' needs
- Provide efficient electricity transmission services
- Meet the challenge to keep costs down when key drivers are pushing costs up

For information about ElectraNet visit www.electranet.com.au.

Contact

For enquiries about this revised proposed pricing methodology please contact:

Bill Jackson
Senior Regulatory Consultant – Compliance and Pricing
ElectraNet
52-55 East Terrace
Adelaide SA 5000

enquiries@electranet.com.au

Table of Contents

1. Introduction	1
2. Interpretation	2
3. Prescribed Transmission Services	2
4. Rules Requirements	3
5. Pricing Methodology Guidelines Requirements	3
6. Revised Proposed Pricing Methodology	4
6.1 Background	4
6.2 Co-ordinating Network Service Provider	5
6.3 Aggregate Annual Revenue Requirement	5
6.4 Categories of transmission services	6
6.5 Cost allocation	6
6.5.1 Assets attributable to prescribed entry services and prescribed exit services	6
6.6 Calculation of the attributable cost share for each category of service	7
6.7 Calculation of the Annual Service Revenue Requirement (ASRR)	8
6.8 Allocation of the ASRR to transmission network connection points	8
6.8.1 Prescribed entry services	8
6.8.2 Prescribed exit services	10
6.8.3 Prescribed Transmission Use of System (TUOS) services	10
6.9 Modified Cost Reflective Network Pricing Methodology	12
6.9.1 Load and generation data	12
6.9.2 Network support costs	13
6.10 Transmission prices and charges	14
6.10.1 Prescribed entry and exit services prices	14
6.10.2 Prescribed TUOS services – locational component prices and charges	14
6.10.3 Prescribed TUOS services – non-locational component prices and charges	15
6.11 Prescribed common service prices and charges	17
6.12 Standby service arrangements	17
6.13 Excess demand charge	17
6.14 Setting of TUOS locational prices between annual price publications	18
7. Billing Arrangements	18
7.1 Billing for prescribed transmission services	18
7.2 Payments between Transmission Network Service Providers	19
8. Prudential Requirements	19
8.1 Prudential requirements for prescribed transmission services	19
8.2 Capital contribution or prepayment for a specific asset	19
9. Prudent Discounts	20
10. Monitoring and Compliance	20
11. Description of Pricing Methodology Differences	20

ElectraNet Revised Proposed Pricing Methodology – 3 April 2008

11.1	Costs that could be allocated to more than one category of service.....	20
11.2	Provision for relaxation of TUOS locational side constraints.....	21
12.	Additional information requirements.....	21
13.	Conclusion.....	22
	Appendix A - Structure of Transmission Pricing under Part J of Rules.....	23
	Appendix B - Details of Cost Allocation Process.....	24
	Appendix C - Cost Reflective Network Pricing Methodology	26
	Appendix D - Ratings Adjustment for Calculating Utilisation Factors	28
	Appendix E - Priority Ordering Methodology	29

1. Introduction

ElectraNet Pty Ltd (ElectraNet) is the principal electricity *Transmission Network Service Provider* (TNSP) in South Australia.

This revised proposed *pricing methodology*, for the regulatory period from 1 July 2008 to 30 June 2013, is submitted to the Australian Energy Regulator (AER) in accordance with the requirements of Chapter 6A of the National Electricity Rules (the Rules), the AER's *pricing methodology guidelines* and the agreed interim requirements issued by the AER pursuant to clause 11.8 of the Rules.

ElectraNet submitted a proposed *pricing methodology* to the AER on 31 May 2007 and on 7 November 2007 elected to have its proposed *pricing methodology* assessed against the AER's *pricing methodology guidelines*, as provided for under clause 2.3(a) of the agreed interim arrangements.

In making this election, ElectraNet anticipated that the AER would reject its proposed *pricing methodology*, thereby providing the opportunity for ElectraNet to submit a revised proposed *pricing methodology* consistent with the AER's recently published *pricing methodology guidelines*¹.

ElectraNet noted that its proposed *pricing methodology* does not comply with the *pricing methodology guidelines* because it does not²:

- Detail the *Co-ordinating Network Service Provider* arrangements in place under clause 6A.29.1 of the Rules;
- Detail the methodology for implementation of the priority ordering approach under clause 6A.23.2(d) of the Rules
- Describe how assets which may be attributable to both *prescribed entry services* and *prescribed exit services* will be allocated;
- Describe billing arrangements as outlined in clause 6A.27 of the Rules;
- Describe prudential requirements as outlined in clause 6A.28 of the Rules;
- Describe how monitoring of compliance will be undertaken; and
- Provide hypothetical worked examples.

Accordingly the AER rejected ElectraNet's proposed *pricing methodology* and directed that a revised proposed *pricing methodology* be submitted by 14 December 2007.

¹ The AER's pricing methodology guidelines were published on 29 October 2007 and were unavailable at the time ElectraNet submitted its proposed pricing methodology. In effect ElectraNet elected to submit a revised proposed pricing methodology consistent with the AER guidelines thereby promoting greater National consistency in transmission pricing.

² In accordance with clause 2.3(e) of the agreed interim requirements ElectraNet is required to provide an explanation of the reasons why ElectraNet's proposed pricing methodology was not compliant with the *pricing methodology guidelines*.

ElectraNet Revised Proposed Pricing Methodology – 3 April 2008

This revised proposed *pricing methodology* addresses the additional information requirements identified above and also removes references to the old Chapter 6 of the Rules which had been required under the agreed interim arrangements. ElectraNet is confident that its revised proposed *pricing methodology* fully satisfies the requirements of the Rules and the *pricing methodology guidelines*.

2. Interpretation

All terms in this revised proposed *pricing methodology* that are italicised have the meaning given to them in the *pricing methodology guidelines* or, where no definition is provided in that document, the Rules.

A reference to the Rules is taken to be a reference to the current version of the National Electricity Rules, version 19, which commenced operation on 6 March 2008 as amended from time to time.

A reference to the old Rules is taken to be a reference to version 9 of the National Electricity Rules which was operative between 27 July 2006 and 15 November 2006.

3. Prescribed Transmission Services

ElectraNet's revised proposed *pricing methodology* relates to the provision of *prescribed transmission services* in the South Australian region by ElectraNet and Murraylink³. These services include:

- Shared transmission services provided to customers directly connected to the transmission network and connected network service providers (*prescribed TUOS services*);
- Connection services provided to connect the ETSA Utilities distribution network to the transmission network (*prescribed exit services*);
- Grandfathered connection services provided to generators and customers directly connected to the transmission network that were in place or committed to be in place on 9 February 2006 (*prescribed entry services and prescribed exit services*); and
- Services required under the Rules or in accordance with jurisdictional electricity legislation that are necessary to ensure the integrity of the transmission network, including through the maintenance of power system security and assisting in the planning of the power system (*prescribed common transmission services*).

For the avoidance of doubt the revised proposed *pricing methodology* does not relate to the provision of *negotiated transmission services* or other *transmission services* provided by ElectraNet (non-regulated transmission services) that are not subject to economic regulation under Chapter 6A of the Rules.

³ In accordance with clause 6A.29.1 of the Rules, ElectraNet is the *co-ordinating network service provider* for South Australia and collects both ElectraNet's and the Murraylink Transmission Company's regulated revenue entitlement via ElectraNet's transmission services prices.

4. Rules Requirements

Clause 6A.24.1 of the Rules states that the *pricing methodology* is a methodology, formula, process or approach that when applied by a TNSP:

- (1) allocates the *aggregate annual revenue requirement (AARR)* for *prescribed transmission services* to:
 - (i) the *categories of prescribed transmission services* for that provider; and
 - (ii) *transmission network connection points of Transmission Network Users*; and
- (2) determines the structure of the prices that a *Transmission Network Service Provider* may charge for each of the *categories of prescribed transmission services* for that provider.

The Rules also require that the *pricing methodology* satisfy principles and guidelines established by the Rules. In particular, clause 6A.10.1(e) of the Rules requires that the revised proposed *pricing methodology* must:

- (1) give effect to and be consistent with the *Pricing Principles for Prescribed Transmission Services* (that is to say, the principles set out in rule 6A.23); and
- (2) comply with the requirements of, and contain or be accompanied by such information as is required by, the *pricing methodology guidelines* made for that purpose under rule 6A.25.

5. Pricing Methodology Guidelines Requirements

The *pricing methodology guidelines* supplement and elaborate on the pricing principles contained in Chapter 6A of the Rules in so far as they specify or clarify:

- the information that is to accompany a proposed *pricing methodology*;
- permitted pricing structures for the recovery of the locational component of providing *prescribed TUOS services*;
- permitted postage stamp pricing structures for *prescribed common transmission services* and the recovery of the adjusted non-locational component of providing *prescribed TUOS services*;
- the types of *transmission system* assets that are *directly attributable* to each category of *prescribed transmission services*; and
- those parts of a proposed *pricing methodology*, or the information accompanying it that will not be publicly disclosed without the consent of the TNSP.

All key features of ElectraNet's existing and revised proposed *pricing methodology* are permissible under the *pricing methodology guidelines*. These include:

ElectraNet Revised Proposed Pricing Methodology – 3 April 2008

- Calculation of the locational component of *prescribed TUOS services* costs using the *modified cost reflective network pricing methodology*;
- The locational *prescribed TUOS services* price being based on *contract agreed maximum demand*; and
- The postage stamp pricing structures for the non-locational component of *prescribed TUOS services* and *prescribed common transmission services* being based on *contract agreed maximum demand* or historical energy.

The material additional requirements which arise from the *pricing methodology guidelines* include the requirement to:

- Detail the methodology for implementation of the priority ordering approach under clause 6A.23.2(d) of the Rules including a worked example;
- Describe how asset costs allocated to *prescribed entry services* and *prescribed exit services* at a connection point, which may be attributable to multiple *transmission network users*, will be allocated;
- Detail billing arrangements as outlined in clause 6A.27 of the Rules;
- Detail prudential requirements as outlined in clause 6A.28 of the Rules;
- Provide specified hypothetical worked examples; and
- Detail how ElectraNet intends to monitor and develop records of its compliance with its approved *pricing methodology*, the pricing principles for *prescribed transmission services* (clause 6A.23) and part J of the Rules in general.

6. Revised Proposed Pricing Methodology

6.1 Background

ElectraNet's transmission *pricing methodology*, applicable from 1 January 2003, was developed in accordance with Part C of Chapter 6 of the old Rules⁴.

As provided for under the agreed interim arrangements ElectraNet developed its proposed *pricing methodology* (May 2007) to be consistent with the pricing principles in clause 6A.23 of the Rules and applied the provisions of Part C of Chapter 6 of the old Rules where these supplement the pricing principles.

In effect the provisions of Part C of Chapter 6 of the old Rules were used to provide needed guidance in the absence of the *pricing methodology guidelines* which have subsequently been developed by the AER under clause 6A.25 of the Rules.

As discussed in Section 1, ElectraNet elected to have its proposed *pricing methodology* (May 2007) assessed against the AER's *pricing methodology guidelines*. This has required relatively minor modifications to the proposed *pricing methodology* (May 2007), including to satisfy additional information requirements such as worked examples.

⁴ http://www.electranet.com.au/network_prices.html

ElectraNet Revised Proposed Pricing Methodology – 3 April 2008

The diagram in Appendix A outlines the structure of transmission pricing under part J of the Rules that is applicable to this revised proposed *pricing methodology*.

6.2 Co-ordinating Network Service Provider

In accordance with clause 6A.29.1 of the Rules, ElectraNet is the *Co-ordinating Network Service Provider* for South Australia and collects both ElectraNet's and the Murraylink Transmission Company (MTC)'s regulated revenue entitlements via ElectraNet's prescribed transmission service prices.

MTC is required to advise ElectraNet annually of the Aggregate Annual Revenue Requirement (*AARR*) for its *transmission system* assets which are used to provide *prescribed transmission services* within the South Australian region. It is also required to provide any other information reasonably required by ElectraNet to ensure the proper calculation of prescribed transmission prices in South Australia⁵.

6.3 Aggregate Annual Revenue Requirement

The revenue that a TNSP may earn in any regulatory year of a regulatory control period from the provision of *prescribed transmission services* is known as the *maximum allowed revenue*⁶.

The *AARR* is calculated in accordance with clause 6A.22.1 of the Rules as:

“the *maximum allowed revenue* referred to in clause 6A.3.1 adjusted:

- (1) in accordance with clause 6A.3.2, and
- (2) by subtracting the operating and maintenance costs expected to be incurred in the provision of *prescribed common transmission services*.”

Adjustments in accordance with clause 6A.3.2 could relate to a number of factors including reopening of the revenue determination for capital expenditure, network support pass through, cost pass through, service target performance incentive scheme outcomes and contingent projects.

The costs referred in (2) above are derived from budget projections and include:

- network switching and operations;
- administration and management of the business;
- network planning and development; and
- general overheads.

⁵ This obligation will also apply to any additional *appointing providers* requiring the services of the *co-ordinating network service provider* during the life of this *pricing methodology*.

⁶ Clause 6A3.1 of the Rules.

6.4 Categories of transmission services

ElectraNet's and MTC's AARRs are recovered from transmission charges for the following categories of transmission services:

- *Prescribed entry services* which include assets that are directly attributable to serving a Generator or group of Generators at a single connection point and are deemed prescribed by virtue of the operation of clause 11.6.11 of the Rules;
- *Prescribed exit services* which include assets that are directly attributable to serving a Transmission Customer or group of Transmission Customers at a single connection point and: (a) are deemed prescribed by virtue of the operation of clause 11.6.11 of the Rules; or (b) are provided to Network Service Providers at the boundary of the prescribed transmission network;
- *Prescribed transmission use of system (TUOS) services* which include assets that are shared to a greater or lesser extent by all users across the *transmission system* and are not *prescribed common transmission services, prescribed entry services or prescribed exit services*; and
- *Prescribed common transmission services*, which are services that benefit all Transmission Customers and cannot be reasonably allocated on a locational basis.

6.5 Cost allocation

The first step in calculating prescribed transmission service prices is to allocate the costs of *transmission system* assets to the categories of transmission service in section 6.4 above to the extent to which assets are *directly attributable* to the provision of a category of *prescribed transmission services*.

The delineation between the assets that provide *prescribed entry services, prescribed exit services, prescribed TUOS services* and *prescribed common transmission services* is set out in clause 2.4 of the *pricing methodology guidelines*.

The cost allocation process assigns the optimised replacement cost (ORC)⁷ of all *prescribed transmission services* assets to either *prescribed common transmission services* (assets that benefit all transmission customers) or individual network pricing branches (transmission lines and transformers). Each network pricing branch is then defined as entry, exit or shared network. This cost allocation process is explained in more detail in Appendix B.

6.5.1 Assets attributable to prescribed entry services and prescribed exit services

In the case of a shared connection asset (such as a transformer) serving multiple transmission connection points, which may provide both *prescribed entry services* and *prescribed exit services*, the cost of the shared connection asset will be allocated to the appropriate category or categories of *prescribed transmission services* using an appropriate causal cost allocator⁸. For example:

⁷ Consistent with clause 6A.22.3(b) of the Rules

⁸ This is consistent with ElectraNet's proposed *cost allocation methodology* which is used to allocate costs between *prescribed transmission services, negotiated transmission services* and *non-regulated transmission services*.

ElectraNet Revised Proposed Pricing Methodology – 3 April 2008

- Generation or reactive plant nameplate rating capacity or agreed maximum demand (AMD) supplied by the specified transmission category as a percentage of the total capacity and demand of all transmission categories at that location: Costs are attributable based on the capacity and/or AMD agreed upon by the customer(s);
- Unit of plant method: Costs are allocated based on the number of units of plant installed (typically circuit breakers) where these units of plant can be attributed to a particular category of transmission service; or
- As negotiated between the connecting parties.

This process would also be adopted to allocate shared costs to individual connection points.

6.6 Calculation of the attributable cost share for each category of service

The second step in calculating prescribed transmission service prices is the calculation of the attributable cost shares. The attributable cost share for each category of service is calculated in accordance with clause 6A.22.3 of the Rules as the ratio of:

- the costs of the *transmission system assets directly attributable* to the provision of that category of *prescribed transmission services* (as determined in section 6.5 above); to
- the total costs of all the TNSP's *transmission system assets directly attributable* to the provision of *prescribed transmission services* (as determined in section 6.5 above).

For example, if the ORC's of prescribed services assets have been allocated to the applicable categories of *prescribed transmission services* as shown in Table 1 then the attributable costs shares are calculated as:

$$\begin{aligned}\text{Attributable cost share}_{\text{EXIT}} &= \text{ORC}_{\text{EXIT}} / \text{ORC}_{\text{TOTAL}} \\ &= \$6,972,222 / \$43,050,000 \\ &= 0.162\end{aligned}$$

with the attributable cost shares of the other categories calculated in the same manner, as shown in Table 2.

Table 1: Costs allocated to categories of prescribed transmission services

Category	ORC
Exit service	6,972,222
Entry service	1,761,111
TUOS service	33,566,667
Common Service	750,000
Total	43,050,000

Table 2: Attributable cost shares

Category	ORC	Attributable cost share
Exit service	6,972,222	0.162
Entry service	1,761,111	0.041
TUOS service	33,566,667	0.780
Common Service	750,000	0.017
Total	43,050,000	1.000

6.7 Calculation of the Annual Service Revenue Requirement (ASRR)

The third step in calculating prescribed transmission service prices is to allocate the *AARR* to each category of prescribed transmission service in accordance with the *attributable cost share* for that category of services.

This allocation results in the *annual service revenue requirement (ASRR)* for that category of services.

Assuming an *AARR* of \$2,504,434 and applying the attributable cost shares determined above the *ASRR* for each category of prescribed services is calculated as:

$$\begin{aligned}
 ASRR_{\text{EXIT}} &= AARR \times \text{Attributable cost share}_{\text{EXIT}} \\
 &= \$2,504,434 \times 0.162 \\
 &= \$405,609
 \end{aligned}$$

with the *ASRRs* of the other categories calculated in the same manner.

Table 3 Annual Service Revenue Requirements

Category	Attributable cost share	Annual Service Revenue Requirement (ASRR)
Exit service	0.162	405,609
Entry service	0.041	102,453
TUOS service	0.780	1,952,741
Common Service	0.017	43,631
Total	1.000	2,504,434

6.8 Allocation of the ASRR to transmission network connection points

The fourth step in calculating prescribed transmission service prices is to allocate the *ASRR* for *prescribed entry services*, *prescribed exit services* and *prescribed TUOS services* to each transmission network connection point in accordance with the principles of clause 6A.23.3 of the Rules.

6.8.1 Prescribed entry services

The whole of the *ASRR* for *prescribed entry services* is allocated to each transmission network connection point in accordance with the *attributable connection*

ElectraNet Revised Proposed Pricing Methodology – 3 April 2008

point cost share for *prescribed entry services* that are provided by the TNSP at that connection point.

The *attributable connection point cost share* for *prescribed entry services* is the ratio of the costs of the *transmission system* assets *directly attributable* to the provision of *prescribed entry services* at that transmission network connection point to the total costs of all the TNSP's *transmission system* assets *directly attributable* to the provision of *prescribed entry services*.

For example, if two generators, Gen A1 and Gen A2 receive *prescribed entry services* and the cost allocation process has allocated the ORCs of assets *directly attributable* to *prescribed entry services* to them as shown in Table 4.

$$\begin{aligned} \text{Attributable connection point cost share}_{\text{GEN A1}} &= \text{ORC}_{\text{GEN A1}} / \text{ORC}_{\text{ENTRY}} \\ &= \$1,033,333 / \$1,761,111 \\ &= 0.587 \end{aligned}$$

with the *attributable connection point cost share* of the other generator being calculated in the same manner as shown in Table 5.

Table 4: Prescribed entry services ORCs

Entry	ORC
Gen A1	1,033,333
Gen A2	727,778
Total ORC of prescribed entry assets	1,761,111

Table 5: Attributable connection point cost shares

Entry	ORC	Attributable connection point cost share
Gen A1	1,033,333	0.587
Gen A2	727,778	0.413
Total	1,761,111	1.000

The *ASRR* allocated to the Gen A1 transmission network connection point is calculated as follows:

$$\begin{aligned} \text{ASRR}_{\text{GEN A1}} &= \text{ASRR}_{\text{ENTRY}} \times \text{Attributable connection point cost share}_{\text{GEN A1}} \\ &= \$102,453 \times 0.587 \\ &= \$60,114 \end{aligned}$$

with the *ASRR* of the other generator connection point being calculated in the same manner.

Table 6: Connection point ASRRs (entry)

Entry	ORC	Attributable connection point cost share	Connection point ASRR
Gen A1	1,033,333	0.587	60,114
Gen A2	727,778	0.413	42,338
Total	1,761,111	1.000	102,453

6.8.2 Prescribed exit services

The whole of the ASRR for *prescribed exit services* is allocated to each transmission network connection points in accordance with the *attributable connection point cost share* for *prescribed exit services* that are provided by the TNSP at that connection point.

The attributable connection point cost share for *prescribed exit services* is the ratio of the costs of the *transmission system assets directly attributable* to the provision of *prescribed exit services* at that transmission network connection point to the total costs of all the *transmission system assets directly attributable* to the provision of *prescribed exit services*.

The ASRRs of the prescribed exit connection points are calculated in the same manner as for the entry connection points.

Table 7: Connection point ASRRs (exit)

Exit	ORC	Attributable connection point cost share	Connection point ASRR
Load A1	2,083,333	0.299	121,198
Load A2	1,405,556	0.202	81,768
Load B1	2,633,333	0.378	153,194
Load C1	850,000	0.122	49,449
Total	6,972,222	1.000	405,609

6.8.3 Prescribed Transmission Use of System (TUOS) services

The prescribed TUOS (shared network) services ASRR is recovered from:

- *Prescribed TUOS services* (locational component); and
- *Prescribed TUOS services* (the adjusted non-locational component).

Clause 6A.23.3(c)(1) of the Rules requires that:

“a share of the ASRR (the locational component) is to be adjusted by subtracting the estimated *auction amounts* expected to be distributed to the TNSP under clause 3.18.4 from the *connection points* for each relevant *directional interconnector* and this adjusted share is to be allocated as between such *connection points* on the basis of the estimated proportionate use of the relevant *transmission system assets* by each of those customers, and the *CRNP methodology* and *modified CRNP methodology* represent two permitted means of estimating proportionate use”.

ElectraNet Revised Proposed Pricing Methodology – 3 April 2008

Consistent with clause 6A.23.3(c)(1) of the Rules, the locational share of the *prescribed TUOS services ASRR* is adjusted for estimated inter-regional settlements residue proceeds by converting the estimated proceeds to an equivalent asset replacement cost⁹ that is offset against the asset replacement cost of the relevant interconnector network pricing branches for input to the *modified cost reflective network pricing methodology (modified CRNP methodology)*¹⁰.

The adjusted share of the ASRR is allocated between connection points on the basis of the estimated proportionate use of the relevant *transmission system* assets by each customer using the *modified CRNP methodology*.

ElectraNet obtained approval from the ACCC to use a *modified CRNP methodology* to determine TUOS Usage (locational) charges and prices in conjunction with its 2002 revenue cap decision.

ElectraNet proposes to continue applying the *modified CRNP methodology* as described in section 6.9.

The *CRNP methodology* allocates a proportion of shared network costs to individual customer connection points. ElectraNet applies the *CRNP methodology* using the TPRICE *cost reflective network pricing* software used by most TNSPs in the NEM.

The *CRNP methodology* requires three sets of input data:

- An electrical (loadflow) model of the network;
- A cost model of the network (the results of the cost allocation process described in Appendix B); and
- An appropriate set of load/ generation patterns.

Appendix C describes the *CRNP methodology* in more detail.

The remainder of the *ASRR* (the pre-adjusted non-locational component) is to be adjusted:

- by subtracting the amount (if any) referred to in clause 6A.23.3(e) of the Rules;
- by subtracting or adding any remaining settlements residue (not being settlements residue referred to in the determination of the locational component but including the portion of settlements residue due to intra-regional loss factors) which is expected to be distributed or recovered (as the case may be) to or from the TNSP in accordance with clause 3.6.5(a) of the Rules;
- for any *over-recovery amount* or *under-recovery amount* from previous years;
- for any amount arising as a result of the application of clause 6A.23.4(h) and (i) of the Rules; and

⁹ Using the same rate of return that is subsequently used to determine prescribed TUOS charges – locational component.

¹⁰ In this way estimated settlements residue auction proceeds recover a portion of the *AARR* allocated to shared network costs on a locational basis.

- for any amount arising as a result of the application of prudent discounts in accordance with clause 6A.26.1(d)-(g) of the Rules,

6.9 Modified Cost Reflective Network Pricing Methodology

The essential difference between standard *CRNP methodology* and *modified CRNP methodology* is that in calculating the network costs to be recovered on a locational basis (i.e. prescribed TUOS – locational component):

- The standard *CRNP methodology* allocates shared network costs to connection points on the basis of optimised replacement costs and assumes a 50 - 50 split between the locational and non-locational components of network charges;
- The *modified CRNP methodology* uses utilisation adjusted replacement costs. An average rate of return¹¹ is applied to the resulting costs allocated to each connection point to determine its share of the locational component of shared network charges (i.e. the arbitrary 50 - 50 split used with the standard *CRNP methodology* is removed). Prescribed TUOS – non-locational charges recover the balance of network costs (the costs not recovered by prescribed TUOS – locational charges).

The *modified CRNP methodology* is intended to encourage better utilisation of existing assets by discounting the costs allocated to under-utilised elements relative to those that are more heavily utilised.

TPRICE calculates utilisation factors based on the maximum loading of each network pricing branch over the range of operating conditions analysed and pricing branch ratings provided as input to TPRICE.

In determining the utilisation factors required by Schedule 6A.3.3(2) of the Rules the *modified CRNP methodology* ensures that asset utilisation is based on the maximum flow allowed on network elements within the normal operating constraints of the network to prevent inefficient discounting of costs in the meshed network.

As TPRICE performs its calculations based on system normal operating conditions (i.e. with all elements in service) and does not carry out contingency analysis that is representative of the normal operating constraints of the network, it is necessary to apply an adjustment factor reducing branch ratings for input to TPRICE to ensure that utilisation factors appropriately take into account network contingencies.

Appendix D describes the ratings adjustment for calculation of utilisation factors in more detail.

6.9.1 Load and generation data

As noted in Appendix C, the choice of operating conditions is important in developing prices using the *CRNP methodology*. ElectraNet has flexibility in the choice of operating conditions, but notes that the old Rules set out the principles that should apply in determining the sample of operating conditions considered. Of particular note is the requirement that operating conditions to be used are to include at least 10 days

¹¹ The rate of return is calculated so that prescribed TUOS – locational charges would recover the full cost of the shared network when all network elements are assumed to be 100% utilised.

with high system demand, to ensure that loading conditions, which impose peak flows on all transmission elements, are captured.

Schedule 6A.3.2(3) of the Rules is less prescriptive requiring that the allocation of dispatched generation to loads be over a range of actual operating conditions from the previous financial year and that the range of operating scenarios be chosen so as to include the conditions that result in most stress on the transmission network and for which network investment may be contemplated.

Clause 2.2(a) of the *pricing methodology guidelines* requires that prices for the recovery of the locational component of *prescribed TUOS services* are based on demand at times of greatest utilisation of the transmission network and for which network investment is most likely to be contemplated in accordance with clause 6A.23.4(e) of the Rules.

The use made of the network by particular loads and generators will vary considerably depending on the load and generation conditions on the network. For this reason a number of operating scenarios are examined with different load and generation patterns.

In selecting those operating scenarios it is important to recognise that the operating conditions that impose most stress on particular network elements may occur at times other than for system peak demand.

The TPRICE capacity method of cost allocation (used by ElectraNet) automatically captures the peak loading conditions on network elements from the sample of operating conditions analysed.

ElectraNet, therefore, uses the full year of operating data (i.e. 365 days of half hourly data) to avoid the need for judgement concerning an appropriate set of operating conditions.

Consistent with clause 2.2(f) of the *pricing methodology guidelines* where actual operating conditions from the previous complete financial year are unavailable for a connection point, as would be the case for a new connection point, an estimate based on the *contract agreed maximum demand* and other characteristics of the load would be used to allocate costs to that connection point.

6.9.2 Network support costs

An estimate of network support costs is converted to an equivalent asset replacement cost¹² that is added to the asset replacement cost of the transmission assets these services support.

ElectraNet recovers these costs on a locational basis as part of its *modified CRNP methodology*.

Recovery of network support costs on a locational basis is appropriate given that the alternative network augmentation costs would be recovered on this basis.

¹² Using the same rate of return that is subsequently used to determine prescribed TUOS charges – locational component (TUOS Usage charges under old Rules).

6.10 Transmission prices and charges

6.10.1 Prescribed entry and exit services prices

Prescribed entry services and *prescribed exit services* prices are calculated to recover the *prescribed entry and prescribed exit services ASRRs* from the network users who are served by the relevant connection assets.

The *prescribed entry services ASRR* is recovered as a fixed annual charge for each entry point, which is recovered on the basis of a fixed \$/day entry price.

Similarly, the *prescribed exit services ASRR* is recovered as a fixed annual charge for each exit point, which is recovered on the basis of a fixed \$/day exit price.

6.10.2 Prescribed TUOS services – locational component prices and charges

Consistent with the provisions of clause 2.2(c)(1) of the *pricing methodology guidelines* locational prices will be determined on the basis of *contract agreed maximum demand*¹³.

The prescribed TUOS locational *ASRR* described in 6.8.3 is priced on a *contract agreed maximum demand* basis (\$/MW/day), where the *contract agreed maximum demand* is specified in, and re-negotiated in accordance with, customer connection agreements.

The modified CRNP methodology outlined in S6A.3 of the Rules and detailed in this revised proposed *pricing methodology* describes the process for cost allocation for the locational component of *prescribed TUOS services*, which results in a lump sum dollar amount to be recovered at each connection point as described in Appendix C.

This lump sum dollar amount is divided by the product of the number of days in the forthcoming financial year and the *contract agreed maximum demand* (prevailing at the time transmission prices are published) to calculate the locational price at each connection point¹⁴ providing *prescribed TUOS services* expressed as \$/MW/day.

As provided for under clause 6A.23.4(f) of the Rules TUOS locational prices must not change by more than 2% per annum at connection points relative to the load weighted average TUOS locational price for the region. The balance of any revenue shortfall or over recovery resulting from these price caps is recovered or offset as appropriate by adjusting TUOS non-locational prices and charges.

As further provided for under clause 6A.23.4(g) of the Rules the change specified above ‘may exceed 2 per cent per annum if, since the last prices were set:

- (1) the *load* at the *connection point* has materially changed;

¹³ Referred to as the Agreed Maximum Demand (AMD) in ElectraNet transmission connection agreements (TCA). The methodology for dealing with exceedance of *contract agreed maximum demand* is as specified in transmission connection agreements and summarised in section 6.13.

¹⁴ The connection point for the purposes of determining the prescribed TUOS prices and prescribed TUOS charges will be the agreed point (or points) of supply between ElectraNet and the transmission network user. This is the point at which *contract agreed maximum demand* is defined in transmission connection agreements and historical or current metered energy measured.

ElectraNet Revised Proposed Pricing Methodology – 3 April 2008

- (2) in connection with that change, the *Transmission Customer* requested a renegotiation of its *connection agreement* with the *Transmission Network Service Provider*; and
- (3) the AER has approved the change of more than 2 per cent per annum.”

The effect of this provision is to set the prescribed TUOS – locational price at a connection point with a material change in load on the same basis as a new connection point.

In the event that a Transmission Customer requests a material change in *contract agreed maximum demand* at an existing connection point, ElectraNet will seek approval from the AER to set the prescribed TUOS – locational price as intended by clause 6A.23.4(g) of the Rules.

Prescribed TUOS locational charges are determined for each connection point providing *prescribed TUOS services* by multiplying the prescribed TUOS – locational price by the *contract agreed maximum demand* (prevailing during the billing period concerned) for that exit point, determined in accordance with the customer's connection agreement, and multiplying this amount by the number of days in the billing period.

For the avoidance of doubt forecast prescribed TUOS locational charges will be calculated using the *contract agreed maximum demand* prevailing at the time prices are determined as distinct from the actual charges which will be calculated using the *contract agreed maximum demand* prevailing during the billing period concerned.

Any over or under recovery of prescribed revenue arising from variances between forecast *contract agreed maximum demands* and the *contract agreed maximum demands* used for calculating charges will be addressed by way of an under or over recovery adjustment when calculating prices for the following financial year.

6.10.3 Prescribed TUOS services – non-locational component prices and charges

Prices for recovery of the adjusted non-locational component of *prescribed TUOS services* will be set on a postage stamp basis in accordance with clause 6A.23.4(j) of the Rules.

Consistent with the provisions of clause 2.3(c)(1) of the *pricing methodology guidelines* postage stamped prices will be determined on the basis of *contract agreed maximum demand* or historical energy and calculated annually as follows.

Each financial year ElectraNet will determine the following two prices:

- An energy based price that is a price per unit of historical metered energy or current metered energy at a connection point expressed as \$/MWh; and
- a *contract agreed maximum demand* price that is a price per unit of *contract agreed maximum demand* at a connection point expressed as \$/MW/day.

Either the energy based price or the *contract agreed maximum demand* price will apply at a connection point providing *prescribed TUOS services* except for those connection points where a transmission customer has negotiated reduced charges for

ElectraNet Revised Proposed Pricing Methodology – 3 April 2008

adjusted non-locational component of *prescribed TUOS services* in accordance with clause 6A.26.1 of the Rules.

The energy based price and the *contract agreed maximum demand* price will be determined so that:

- a transmission customer with a load factor in relation to its connection point equal to the median load factor for connection points with transmission customers connected to the transmission network in the region or regions is indifferent between the use of the energy based price and the *contract agreed maximum demand* price; and
- the total amount to be recovered by the adjusted non-locational component of *prescribed TUOS services* does not exceed the *ASRR* for this category of prescribed transmission service.

When applying the energy based price, the prescribed TUOS – non locational component charge for a billing period will be calculated for each connection point by:

- multiplying the energy based price by the metered energy offtake at that connection point in the corresponding billing period two years earlier (i.e. *historical metered energy offtake*); or
- multiplying the energy based price by the metered energy offtake at that connection point in the same billing period (*current metered energy offtake*) if the *historical metered energy offtake* is unavailable; or
- multiplying the energy based price by the *current metered energy offtake* if the *historical metered energy offtake* is significantly different to the current metered energy off take. This method of calculation is only expected to be applied where the conditions necessary to enact clause 6A.23.4(g)¹⁵ of the Rules have been satisfied or a connection point is operated in a standby arrangement as detailed in section 6.12 of this *pricing methodology*.

When applying the *contract agreed maximum demand* price, the prescribed TUOS – non-locational component charge for a billing period will be calculated for each connection point by multiplying the *contract agreed maximum demand* price by the *contract agreed maximum demand* for the *connection point* (prevailing during the billing period concerned) and multiplying this amount by the number of days in the billing period.

For the avoidance of doubt forecast prescribed TUOS non-locational charges will be calculated using the *contract agreed maximum demand* prevailing at the time prices are determined as distinct from the actual *contract agreed maximum demand* based charges which will be calculated using the *contract agreed maximum demand* prevailing during the billing period concerned.

Any over or under recovery of prescribed revenue arising from variances between forecast *contract agreed maximum demands* and the *contract agreed maximum demands* used for calculating charges will be addressed by way of an under or over recovery adjustment when calculating prices for the following financial year.

¹⁵ That being the clause which allows for the relaxation of the side constraints on TUOS locational prices at a connection point.

ElectraNet Revised Proposed Pricing Methodology – 3 April 2008

The energy based price or the *contract agreed maximum demand* price that applies for the adjusted non-locational component of *prescribed TUOS services* at a connection point will be the one which results in the lower estimated charge for that prescribed transmission service.

6.11 Prescribed common service prices and charges

Prices for *prescribed common transmission services* will be set on a postage stamp basis in accordance with clause 6A.23.4(d) of the Rules.

Consistent with the provisions of clause 2.3(c)(1) of the *pricing methodology guidelines* postage stamped prices will be determined on the basis of *contract agreed maximum demand* or historical energy and calculated in a manner identical to that described for TUOS non-locational charges in the previous section.

In accordance with clause 6A.23.3(f) of the Rules the operating and maintenance costs expected to be incurred in the provision of *prescribed common transmission services*, which are deducted from the *maximum allowed revenue* to form the *AARR*, are added to the *ASRR* for *prescribed common transmission services* and recovered through *prescribed common service prices and charges*.

6.12 Standby service arrangements

If a customer requires a connection point to provide energy from the transmission network on a standby basis, such as to cover the outage of onsite generation, the customer will pay *prescribed exit services* charges and *prescribed TUOS services – locational component* charges as usual, but will only pay *prescribed TUOS services – non-locational component* charges and *prescribed common transmission services* charges during times that the standby service is actually utilised in energy delivery to the customer.

More specifically, prescribed transmission charges will be determined as follows:

- *Prescribed exit service* charges: as detailed in section 6.10.1;
- *Prescribed TUOS locational* charges: based on the prevailing *contract agreed maximum demand* and *prescribed TUOS services – locational component* price as detailed in section 6.10.2, and
- *Postage stamped prescribed TUOS non-locational service* charges and *prescribed common transmission service* charges: based on *current metered energy offtake* in the billing period as detailed in sections 6.10.3 and 6.11.

For the avoidance of doubt where standby arrangements are required the customer's connection agreement must specify a *contract agreed maximum demand* and excess demand charges as detailed in section 6.13 will apply.

6.13 Excess demand charge

If the customer's actual maximum demand exceeds the *contract agreed maximum demand* level at any time during the financial year then an Excess Demand Charge applies and the actual maximum demand will become the *contract agreed maximum demand*, in accordance with the customer's connection agreement.

ElectraNet Revised Proposed Pricing Methodology – 3 April 2008

In addition, ElectraNet will recover from the customer the incremental charges the customer would have paid to ElectraNet during the entire financial year if the *contract agreed maximum demand* had been the actual maximum demand.

The Excess Demand Charge is determined by multiplying the charge rate specified in ElectraNet's published Transmission Service Price Schedule (\$/kW) by the amount by which the maximum contract demand has been exceeded (kW) or, where applicable, in accordance with the customer's connection agreement.

The charge rate (\$/kW) is calculated as three times the maximum revenue, which ElectraNet can earn from prescribed services during the pricing period (\$), divided by the aggregate of all *contracted agreed maximum demands* connected to the transmission network.

6.14 Setting of TUOS locational prices between annual price publications

In the event that ElectraNet is required to set a TUOS locational price at a new connection point or at a connection point where the load has changed significantly¹⁶ after prescribed TUOS service locational prices have been determined and published, an interim price, not subject to the side constraints of clause 6A.23.4(f) of the Rules, will be determined. This will be calculated using the prevailing pricing models with demands estimated in a manner consistent with clause 2.2(f) of the *pricing methodology guidelines*.

A price subject to the side constraints of clause 6A.23.4(f) of the Rules will be determined and published at the next annual price determination.

7. Billing Arrangements

7.1 Billing for prescribed transmission services

Consistent with clause 6A.27.1 of the Rules, ElectraNet will calculate the transmission service charges payable by *Transmission Network Users* for each connection point in accordance with the transmission service prices published under clause 6A.24.2.

Where charges are determined for *prescribed transmission services* from metering data, these charges will be based on kW or kWh obtained from the metering data managed by NEMMCO.

ElectraNet will issue bills to *Transmission Network Users* for *prescribed transmission services* which satisfy or exceed the minimum information requirements specified in clause 6A.27.2 of the Rules on a monthly basis or as specified in the transmission connection agreement.

Consistent with clause 6A.27.3 of the Rules a *Transmission Network User* must pay charges for *prescribed transmission services* properly charged to it and billed in accordance with this *pricing methodology* by the date specified on the bill.

¹⁶ For an existing connection point this would be subject to clause 6A.23.4(g) of the Rules.

7.2 Payments between Transmission Network Service Providers

Consistent with clause 6A.27.4 of the Rules, where ElectraNet is the *Co-ordinating Network Service Provider* under clause 6A.29.1 of the Rules, it will pay to each other relevant *Transmission Network Service Provider* the revenue which is estimated to be collected during the following year by the first provider as charges for *prescribed transmission services* for the use of transmission systems owned by those other *Transmission Network Service Providers*.

Such payments will be determined by ElectraNet as the *Co-ordinating Network Service Provider* for the region.

Financial transfers payable under clause 6A.27.4 of the Rules will be paid in equal monthly instalments or as documented in revenue collection agreements negotiated between the parties.

8. Prudential Requirements

8.1 Prudential requirements for prescribed transmission services

Consistent with clause 6A.28.1 of the Rules, ElectraNet may require a *Transmission Network User* to establish prudential requirements for either or both connection services and transmission use of system services. These prudential requirements may take the form of, but need not be limited to, capital contributions, pre-payments or financial guarantees.

The requirements for such prudential requirements will be negotiated between the parties and specified in the applicable transmission connection agreement.

8.2 Capital contribution or prepayment for a specific asset

Consistent with clause 6A.28.2 of the Rules, where ElectraNet is required to construct or acquire specific assets to provide prescribed connection services or *prescribed TUOS services* to a *Transmission Network User*, ElectraNet may require that user to make a capital contribution or prepayment for all or part of the cost of the new assets installed.

ElectraNet notes that no capital contributions or prepayments have been made in respect of prescribed transmission services assets as at the date of this proposed *pricing methodology*.

In the event that a capital contribution is required any contribution made will be taken into account in the determination of prescribed transmission service prices applicable to that user by way of a proportionate reduction in the ORC of the asset(s) used for the allocation of prescribed charges or as negotiated between the parties.

In the event that a prepayment is required any prepayment made will be taken into account in the determination of prescribed transmission service prices applicable to that user in a manner to be negotiated between the parties.

The treatment of such capital contributions or prepayments for the purposes of a revenue determination will in all cases be in accordance with the relevant provisions of the Rules.

9. Prudent Discounts

ElectraNet notes that none of its customers currently receive prudent discounts. In the event that a customer does receive prudent discounts in the future, ElectraNet will, in accordance with rule 6A.26.1(d)-(g), adjust the non-locational component of the *ASRR* for *prescribed TUOS services* for the amount of any anticipated under-recovery arising from prudent discounts applied.

10. Monitoring and Compliance

As a regulated business ElectraNet is required to maintain extensive compliance monitoring and reporting systems to ensure compliance with its Transmission Licence, Revenue Determination, the Electricity Transmission Code and the Rules together with numerous other legislative obligations.

In order to monitor and maintain records of its compliance with its approved *pricing methodology*, the pricing principles for *prescribed transmission services*, and part J of the Rules, ElectraNet proposes to:

- Maintain the specific obligations arising from part J of the Rules in its compliance management system;
- Maintain electronic records of the annual calculation of prescribed transmission service prices and supporting information; and
- Periodically subject its transmission pricing models and processes to functional audit by suitably qualified persons.

11. Description of Pricing Methodology Differences

In order to satisfy the requirements of the *pricing methodology guidelines* a significant amount of additional information has been required to be incorporated into this revised proposed *pricing methodology*.

As ElectraNet's existing approved *pricing methodology* is substantially in alignment with chapter 6A of the Rules the majority of required changes involve more fully describing ElectraNet's existing *pricing methodology* and its implementation together with ElectraNet's compliance with specific provisions of Part J of the Rules. A number of hypothetical worked examples have also been incorporated to satisfy these requirements.

In addition to satisfying the additional information requirements two substantive changes have been made in the revised proposed *pricing methodology* compared to the *pricing methodology* applied in the current regulatory period. These changes are summarised below.

11.1 Costs that could be allocated to more than one category of service

ElectraNet's existing cost allocation process allocates substation costs that are *directly attributable* to entry, exit, common and TUOS services and then allocates the residual costs, known as substation local costs, to entry, exit and TUOS services on the basis of the number of pricing branches (transmission lines and transformers)

connected to that substation as described in ElectraNet's existing transmission pricing methodology¹⁷.

Clause 6A.23.2(d) of the Rules introduced a priority ordering concept for the allocation of those costs which could be attributable to more than one category of *prescribed transmission services*.

The cost allocation process has been modified to allocate the substation local costs in accordance with the provisions of clause 6A.23.2(d) of the Rules having regard to the stand alone costs associated with the provision of *prescribed TUOS services* and *prescribed common transmission services* with the remainder being allocated to *prescribed entry and prescribed exit services*. This cost allocation process is described in detail in Appendix E.

This modification will result in relatively minor reallocations of charges between the categories of transmission services. ElectraNet does not expect that the changes to prices resulting from this modification will be material.

11.2 Provision for relaxation of TUOS locational side constraints

The implementation of clause 6A.23.4(g) of the Rules allows for the relaxation of the 2% side constraint for material changes in connection point load or renegotiation of connection agreements, subject to AER approval (discussed in section 6.10.2).

In the event that a Transmission Customer requests a material change in *contract agreed maximum demand* at an existing connection point, ElectraNet will seek approval from the AER to set the prescribed TUOS – locational price as intended by clause 6A.23.4(g) of the Rules.

12. Additional information requirements

A number of additional information requirements arise from the *pricing methodology guidelines* which have not been covered elsewhere in this revised proposed *pricing methodology*. In order to satisfy these requirements ElectraNet notes that it does not:

- consider transitional arrangements are necessary as a result of the implementation of the revised proposed *pricing methodology*;
- have any applicable relevant derogations in accordance with chapter 9 of the Rules; or
- have any applicable transitional arrangements arising from chapter 11 of the Rules.

ElectraNet has not provided a confidential version of this revised proposed *pricing methodology* to the AER in accordance with clause 2.5 of the *pricing methodology guidelines* and hence the provisions of clause 2.1(n) of the *pricing methodology guidelines* are not applicable.

¹⁷ www.electranet.com.au/transmission_prices.html

13. Conclusion

ElectraNet's revised proposed *pricing methodology* for the regulatory control period from 1 July 2008 to 30 June 2013 has been submitted to the AER in accordance with the requirements of Chapter 6A of the Rules and the *pricing methodology guidelines*.

ElectraNet is confident that its revised proposed *pricing methodology* fully satisfies the requirements of the Rules and the *pricing methodology guidelines*.

Appendix A - Structure of Transmission Pricing under Part J of Rules

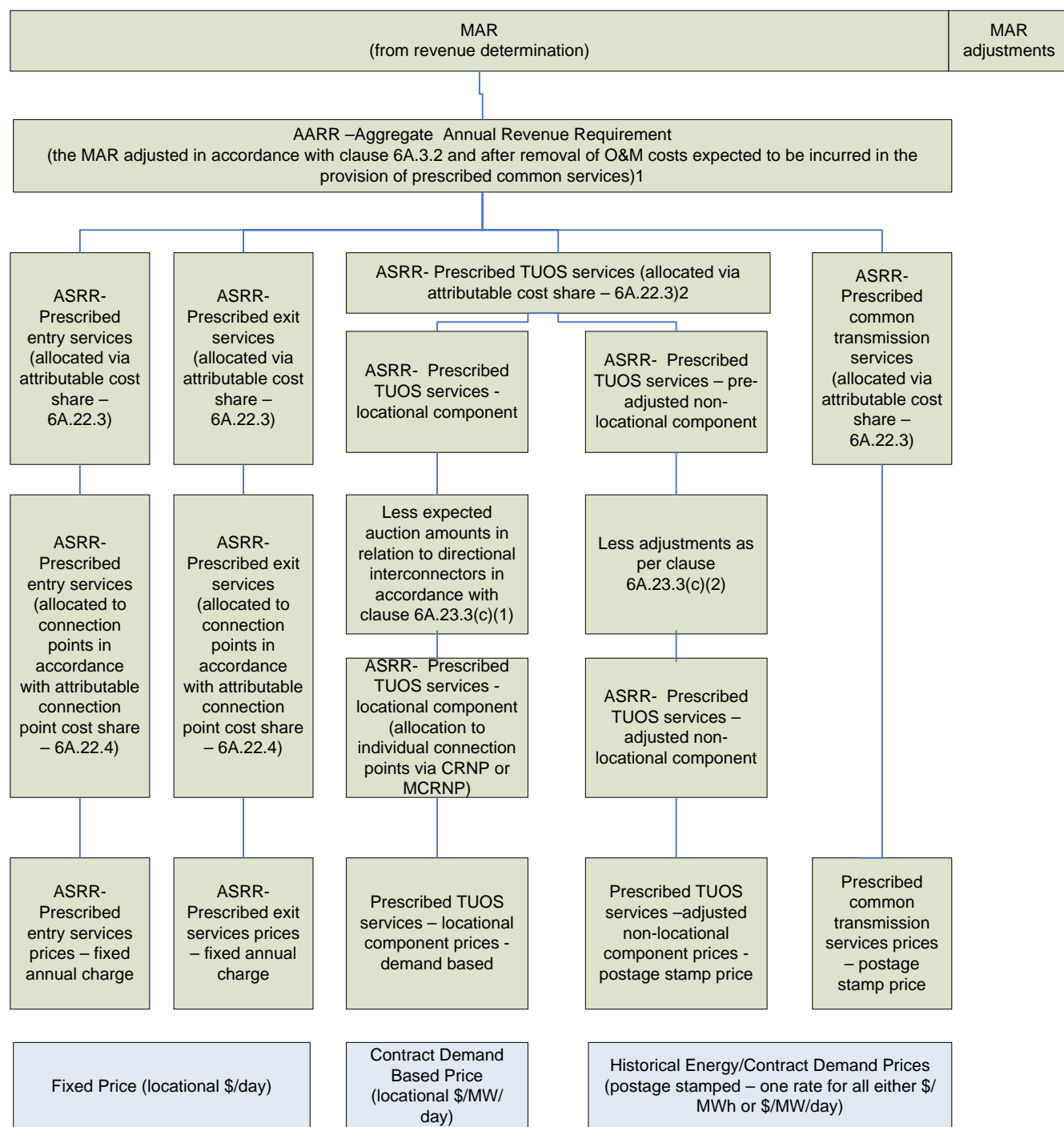

¹ These operating and maintenance costs are not part of the AARR, nor are they part of the ASRR for *prescribed common transmission services*, however they are recovered on a postage stamp basis.

² Shares of the ASRR for *prescribed TUOS services* are to be allocated 50% to the locational component and 50% to the pre-adjusted non-location component or using an alternative allocation as per clause 6A.23.3(d)(2).

Appendix B - Details of Cost Allocation Process

A detailed cost allocation process is used to assign the optimised replacement cost (ORC) of all prescribed service assets to either common service (assets that benefit all transmission customers), network branches (transmission lines or transformers)¹⁸ and prescribed entry or *prescribed exit services* in a manner consistent with Section 2.4 of the *pricing methodology guidelines*.

The cost allocation process is summarised as follows:

Step 1: Initial Cost Allocation

Assets and their ORCs are assigned to one of the following primary asset categories:

- transmission lines;
- transformers;
- circuit breakers;
- common service assets (communications, reactive support, office buildings etc.); and
- substation local assets (ancillary equipment, civil work, and establishment).

The following plant items are not separately identified in the ORC database and are incorporated into the ORC of the associated primary items above:

- Bus work;
- Secondary systems including protection and instrument transformers.

Step 2: Allocation to Categories of Transmission Services

Assets are allocated to the categories of prescribed service in accordance with the provisions of Section 2.4 of the *pricing methodology guidelines*. In the case of circuit breakers each circuit breaker has its replacement cost divided evenly between the branches to which it is *directly attributable*. Any circuit breaker that is not *directly attributable* to any branch together with substation local costs identified in step 1 become subject to the priority ordering process.

In the case of a shared connection asset, such as a transformer, serving multiple transmission connection points which may provide both *prescribed entry services* and *prescribed exit services* the cost of the shared connection asset will be allocated to the appropriate category or categories of *prescribed transmission services* using an appropriate cost allocator¹⁹. For example:

¹⁸ ElectraNet maintains an optimised replacement cost (ORC) model of the transmission network to determine the appropriate ORC of individual transmission lines, transformers, circuit breakers, common service assets and substation local costs.

¹⁹ This is consistent with ElectraNet's proposed cost allocation methodology which is used to allocate costs between *prescribed transmission services*, *negotiated transmission services* and *non-regulated transmission services*.

ElectraNet Revised Proposed Pricing Methodology – 3 April 2008

- Generation or reactive plant nameplate rating capacity or agreed maximum demand (AMD) supplied by the specified transmission category as a percentage of the total capacity and demand of all transmission categories at that location: Costs are attributable based on the capacity and/or AMD agreed upon by the customer(s);
- Unit of plant method: Costs are allocated based on the number of units of plant installed (typically circuit breakers) where these units of plant can be attributed to a particular category of transmission service; or
- As negotiated between the connecting parties.

This process would also be adopted to allocate shared costs to individual connection points.

Step 3: Priority Ordering

In the case of those costs which would be attributable to more than one category of *prescribed transmission services*, specifically the substation local assets identified in Step 1 and those circuit breakers identified as substation local costs in Step 2, costs will be allocated in accordance with the provisions of clause 6A.23.2(d) of the Rules having regard to the stand alone costs associated with the provision of *prescribed TUOS services* and *prescribed common transmission services* with the remainder being allocated to *prescribed entry services* and *prescribed exit services*. The implementation of the priority ordering process is detailed in Appendix E.

Conclusion

The shared network costs resulting from the cost allocation process are used as input to TPRICE, the *Cost Reflective Network Pricing* software that is used by most TNSPs in the NEM.

The entry, exit and common service costs are used as input to the calculation of *prescribed entry services* prices, *prescribed exit services* prices and *prescribed common transmission services* prices.

Appendix C - Cost Reflective Network Pricing Methodology

The *cost reflective network pricing methodology (CRNP methodology)* generally involves the following steps:

- (1) Determining the annual costs of the individual transmission network assets in the optimised transmission network;
- (2) For modified CRNP, adjusting each asset's cost according to its expected utilisation;
- (3) Determining the proportion of each individual network element utilised in providing a transmission service to each point in the network for specified operating conditions.
- (4) Determining the maximum flow imposed on each transmission element by load at each connection point over a set of operating conditions.
- (5) Allocating the costs attributed to the individual transmission elements to loads based on the proportionate use of the elements.
- (6) Determining the total cost (lump sum) allocated to each point by adding the share of the costs of each individual network attributed to each point in the network.

Allocation of Generation to Load

A major assumption in the use of the *CRNP methodology* is the definition of the generation source and the point where load is taken. The approach is to use the "electrical distance" to pair generation to load, in which a greater proportion of load at a particular location is supplied by generators that are electrically closer than those that are electrically remote. In electrical engineering terminology the "electrical distance" is the impedance between the two locations, and this can readily be determined through a standard engineering calculation called the "fault level calculation".

Once the assumption has been made as to the generators that are supplying each load for a particular load and generation condition (time of day) it is possible to trace the flow through the network that results from supplying each load (or generator). The use made of any element by a particular load is then simply the ratio of the flow on the element resulting from the supply to this load to the total use of the load made by all loads and generators in the system.

Operating Conditions for Cost Allocation

The choice of operating conditions is important in developing prices using the *CRNP methodology* or *modified CRNP methodology*. ElectraNet has flexibility in the choice of operating conditions but notes that the old NER set out the principles that should apply in determining the sample of operating conditions considered. Of particular note is the requirement that the operating conditions to be used are to include at least 10 days with high system demand, to ensure that loading conditions, which impose peak flows on all transmission elements, are captured.

Schedule 6A.3.2(3) is less prescriptive requiring that the allocation of dispatched generation to loads be over a range of actual operating conditions from the previous financial year and that the range of operating scenarios is chosen so as to include the conditions that result in most stress on the transmission network and for which network investment may be contemplated.

ElectraNet Revised Proposed Pricing Methodology – 3 April 2008

The use made of the network by particular loads and generators will vary considerably depending on the load and generation conditions on the network. For this reason a number of operating scenarios are examined with different load and generation patterns.

In selecting those operating scenarios it is important to recognise that the operating conditions that impose most stress on particular elements may occur at times other than for system peak demand.

Appendix D - Ratings Adjustment for Calculating Utilisation Factors

When assigning a proportion of shared network costs to individual customer connection points the *modified CRNP methodology* reduces the ORC of each shared network pricing branch (line or transformer) by a utilisation factor that reflects the maximum loading of the branch with respect to its rating.

In determining the appropriate branch rating for entry into TPRICE (used to perform the CRNP calculations) it is important to understand that TPRICE only considers system normal operating conditions whereas the shared network must be able to withstand a single contingency outage without overloading any element consistent with the requirements of the National Electricity Code and the South Australian Electricity Transmission Code.

This means that utilisation factors calculated with respect to equipment ratings (thermal line ratings and transformer nameplate ratings) under system normal conditions would result in artificially low utilisation factors.

This problem can be overcome by reducing the equipment ratings to reflect the maximum flow on a network branch under system normal conditions that would not result in its absolute rating being exceeded in the event of the worst contingency.

The reduced ratings are calculated by examining flows in network elements over a range of peak system operating conditions first for system normal conditions, and then with each meshed network element out of service one at a time. For each network element, the ratio of maximum system normal flow to maximum contingency flow is used to scale down the absolute equipment rating to obtain the reduced rating for input to TPRICE.

This rating adjustment is consistent with Schedule 6.4.1.6(b) of the old Rules, which states in relation to modified CRNP that *“The asset utilisation is to be based on the maximum flow allowed on elements within the normal operating constraints of the network”*.

This process can best be illustrated by an example. A line has an absolute (thermal) rating of 200 MV.A. Network analysis over a range of peak operating conditions shows that this line has a maximum system normal flow of 120 MV.A and a maximum single contingency flow of 160 MV.A. The reduced rating of this line (as input to TPRICE) is $(120/160) * 200$ giving 150 MV.A.

When TPRICE is run, analysis will consider flows on this line over a much wider range of operating conditions (than used in the contingency analysis) some of which may even exceed 120 MV.A. If say the highest usage of this line over the operating conditions assessed by TPRICE is 123 MV.A, then the utilisation factor used by TPRICE with modified CRNP will be 0.82 (123/150).

Appendix E - Priority Ordering Methodology

Rules Requirement

Clause 6A.23.2(d) of the Rules requires that:

Where, as a result of the application of the *attributable cost share*, a portion of the *AARR* would be attributable to more than one category of *prescribed transmission services*, that *attributable cost share* is to be adjusted and applied such that any costs of a *transmission system* asset that would otherwise be attributed to the provision of more than one category of *prescribed transmission services*, is allocated as follows:

- (1) to the provision of *prescribed TUOS services*, but only to the extent of the *stand-alone amount* for that *category of prescribed transmission services*;
- (2) if any portion of the costs of a *transmission system* asset is not allocated to *prescribed TUOS services*, under subparagraph (1), that portion is to be allocated to *prescribed common transmission services*, but only to the extent of the *stand-alone amount* for that *category of prescribed transmission services*;
- (3) if any portion of the costs of a *transmission system* asset is not attributed to *prescribed transmission services* under subparagraphs (1) and (2), that portion is to be attributed to *prescribed entry services* and *prescribed exit services*.

Stand-alone amount is defined as:

For a *category of prescribed transmission services*, the costs of a *transmission system* asset that would have been incurred had that *transmission system* asset been developed, exclusively to provide that *category of prescribed transmission services*.

AEMC Rule determination

In its rule determination the AEMC provided the following guidance on the application of the priority ordering approach for the allocation of costs which can be attributed to more than one type of service²⁰:

“The Commission has maintained a priority ordering approach for the allocation of expenses or costs which can be attributed to more than one type of service. The cascading principle adopted by the Commission is based on the premise that users are seen to be the ‘cause’ of transmission investment. Therefore, costs should be first allocated to prescribed transmission use of system services on a stand-alone basis and then to *prescribed common transmission services*. Where a service/cost cannot justifiably be attributed to TUOS or common services it should be allocated to entry and exist services.”

In developing this methodology ElectraNet has had regard for the following example in the rule determination²¹:

Consider a substation costing \$30 million that was developed:

²⁰ Rule Determination for National Electricity Amendment (Pricing of *Prescribed Transmission Services*) Rule 2006 p5

²¹ Ibid p37

ElectraNet Revised Proposed Pricing Methodology – 3 April 2008

- partly in order to provide *Prescribed TUOS services*;
- partly in order to provide *Prescribed common transmission services*; and
- partly in order to provide *prescribed exit services*.

Then assume that had the substation been developed solely to provide *prescribed TUOS services*, it could have been much smaller and would have cost only \$10 million. Had the substation been developed solely in order to provide *prescribed common transmission services*, it would have cost \$5 million. Finally, had the substation been developed solely in order to provide *prescribed exit services*, it would have cost \$20 million.

The application of the principle would then lead to the \$30 million cost of the substation being attributed to Prescribed Transmission Service categories as follows:

- \$10m to the *prescribed TUOS services ASRR*;
- \$5m to the *prescribed common services ASRR*; and
- the remaining \$15 million to the prescribed exit service *ASRR*.

Objective and General Approach

The proposed allocation methodology relies on the assumption that substation infrastructure and establishment costs are proportionate to the number of high voltage circuit breakers in the substation.

Based on this assumption the appropriate allocator for substation infrastructure and establishment costs for a stand-alone arrangement is the ratio of the number of high voltage circuit breakers²² in the stand-alone arrangement to the number of high voltage circuit breakers in the whole substation.

Proposed Methodology

Step 1: Branch Identification

Identify the branches²³, being the lines, transformers, major reactive devices and exits/entries in the substation which provide prescribed TUOS, *prescribed common transmission services* and exit or entry services, in the substation.

Step 2: Allocation of Circuit Breakers to Branches

For each high voltage circuit breaker in the substation identify the branches directly connected to it. Any circuit breaker that does not directly connect to a branch is excluded from allocation and all costs associated with it are added to the substation infrastructure and establishment cost.

Count the total number of circuit breakers directly connected to branches.

As a general rule, Distribution Network Service Providers (DNSPs) are classified as a prescribed exit service while Generators are classified as a prescribed entry service.

²² Low voltage circuit breakers are not considered in the standalone arrangements.

²³ Described in TDefinition - Branches.

ElectraNet Revised Proposed Pricing Methodology – 3 April 2008

Negotiated services are not part of the regulated asset base and fall outside the priority ordering process detailed in clause 6A.23.2(d) of the Rules.

Step 3.1: Stand-alone arrangements for Prescribed TUOS

With reference to the number of lines providing *prescribed TUOS services* determine the number of circuit breakers required to provide TUOS services of an equivalent standard on a stand-alone basis²⁴. The stand-alone configuration is the simplest substation configuration (in the absence of development) had it been developed to provide a prescribed TUOS service. This may be done by way of a look up of typical stand-alone configurations.

Step 3.2: Stand-alone arrangements for Prescribed common transmission services

With reference to the number of lines providing *prescribed TUOS services* and the devices providing *prescribed common service* determine the number of circuit breakers required to provide *prescribed common transmission services* of an equivalent standard on a stand-alone basis. The stand-alone configuration is the simplest substation configuration (in the absence of development) had it been developed to provide a *prescribed common service*. This may be done by way of a look up of typical stand-alone configurations.

Step 4: Allocation of substation infrastructure and establishment costs

Step 4.1. Allocation of Prescribed TUOS

Allocate a portion of substation infrastructure and establishment costs to prescribed TUOS according to the ratio of the high voltage circuit breakers identified in step 3.1 to the total number of high voltage circuit breakers connected to branches in the substation identified in step 2.

Step 4.2 Calculate the Unallocated Substation Infrastructure Costs after TUOS Allocation

Calculate the Unallocated substation infrastructure cost by subtracting the amount calculated in step 4.1 from the total substation infrastructure amount.

Step 4.3 Allocation of Prescribed Common Service

Allocate a portion of the substation infrastructure and establishment costs to *prescribed common service* based on to the ratio of the high voltage circuit breakers providing *prescribed common transmission services* identified in step 3.2 to the total number of high voltage circuit breakers connected to branches in the substation. If the common service portion of substation infrastructure is greater than the Unallocated costs, then the Unallocated portion only is attributed to *prescribed common service*. In this instance, nothing will be attributed to *prescribed entry and prescribed exit services*.

Step 4.4 Calculate the Unallocated Substation Infrastructure Costs after Common Service Allocation

Calculate the Unallocated substation infrastructure cost by subtracting the amount calculated in step 4.3 from the amount calculated in step 4.2.

²⁴ Whilst an argument can be made that a substation would typically not exist to provide TUOS services alone it is believed that this is inconsistent with the intent of the rule. Accordingly standalone arrangements for prescribed TUOS are taken to require a level of switching consistent with the prevailing bus arrangements.

Step 4.5 Allocation of Prescribed Entry and Exit Service

Allocate the remaining substation infrastructure and establishment costs (calculated in step 4.4) to each branch providing prescribed exit or entry services based on the ratio of the high voltage circuit breakers providing the entry or exit service to the branch to the total number of high voltage circuit breakers providing entry or exit services or in accordance with the cost allocation process in Appendix B as appropriate.

Notes

- Costs are only allocated in step 4 until fully allocated.
- Consistent with clause 6A.23.2(d)(3) of the Rules it is possible that no costs will be attributed to entry and exit services.
- New and existing negotiated service assets are excluded from the analysis as any incremental establishment costs associated with them are taken to be included in the negotiated services charges on a causation basis.
- The assessment of standalone arrangements only needs to be conducted once per substation except where changes to the configuration of the substation occur.

Definition - Branches

As illustrated by the diagrams below a “Branch” is a collection of assets (e.g. lines, circuit breakers, capacitors, buses and transformers) that provide a transmission service.

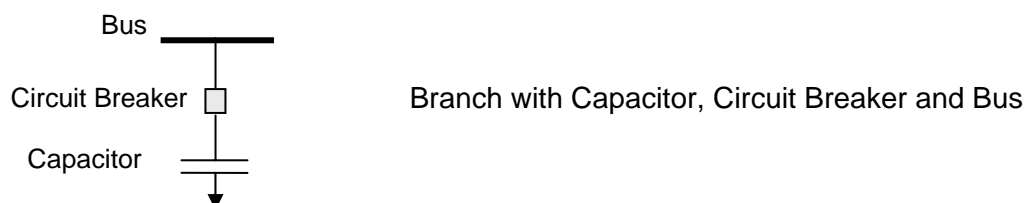
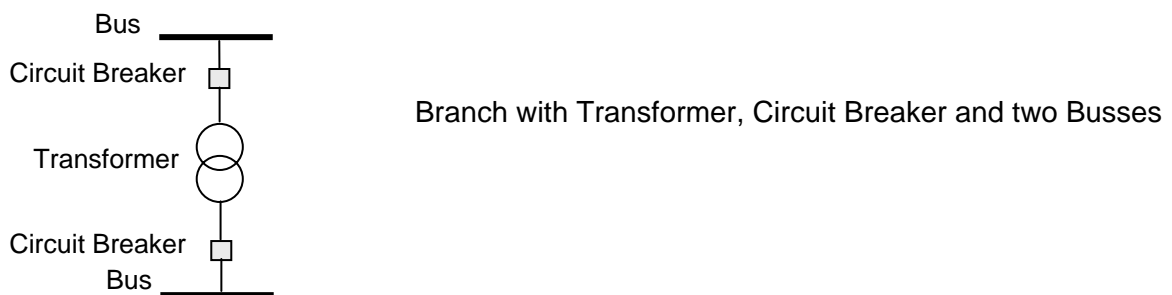
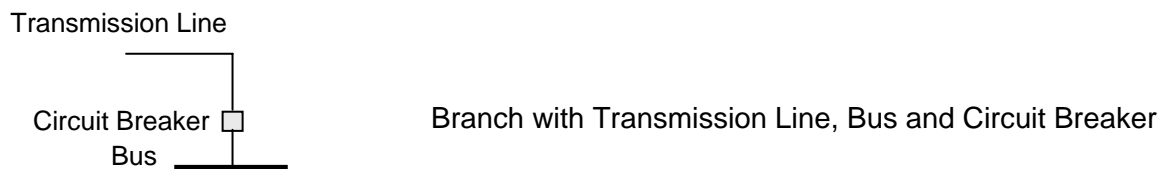

Examples

Example A

Substation Configuration

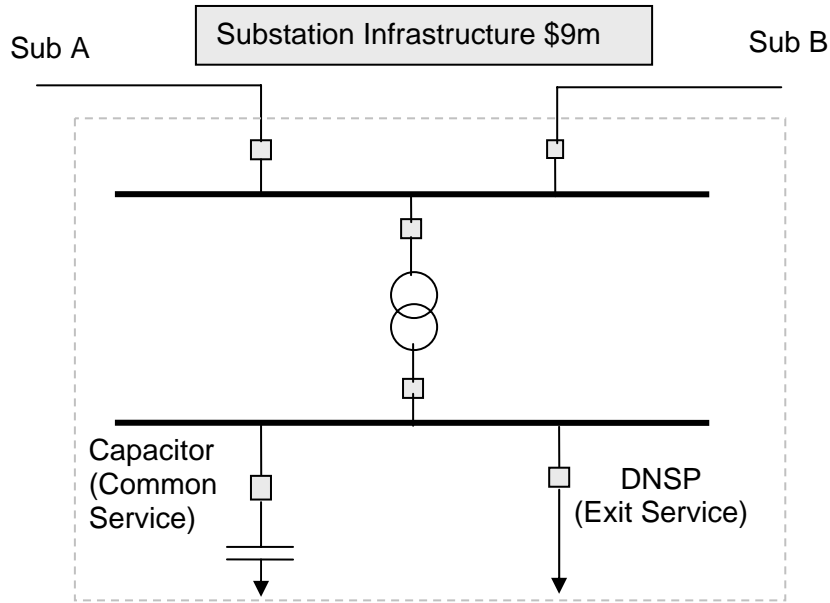

Step 1: The branches are Sub A, Sub B, DNSP, Tie Transformer and PCS.

Step 2: The total number of circuit breakers directly connected to branches is 6.

Step 3.1: The stand-alone arrangement for the provision of *prescribed TUOS services* to an equivalent standard is shown below and consists of 2 circuit breakers.

Stand Alone Prescribed TUOS Service

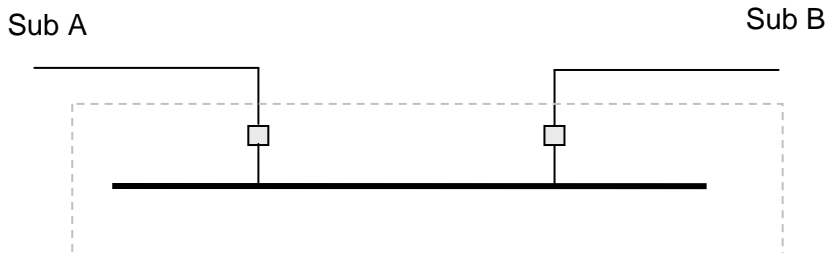

Step 3.2: The stand-alone arrangement for the provision of *prescribed common transmission services* to an equivalent standard is shown below and consists of 3 circuit breakers.

Stand Alone Prescribed Common Service

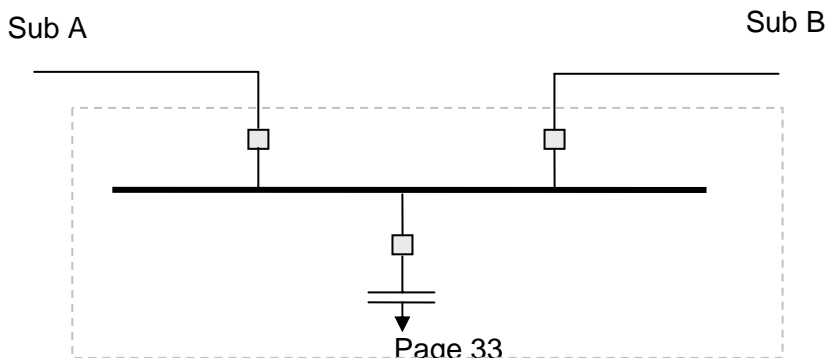

ElectraNet Revised Proposed Pricing Methodology – 3 April 2008

Step 4:

Assume total Infrastructure cost is \$9m.

Costs are allocated to prescribed TUOS in the ratio of the circuit breakers in the stand-alone arrangement to the total circuit breakers.

Infrastructure Cost Allocated to TUOS = $(2/6) \times \$9m = \$3m$

Unallocated = $\$9m - \$3m = \$6m$

Costs are allocated to *prescribed common service* in the ratio of the circuit breakers in the stand-alone arrangement to the total circuit breakers.

Infrastructure Cost allocated to Common Service = $(3/6) \times \$9m = \$4.5m$

Unallocated = $\$6m - \$4.5m = \$1.5m$

Remainder of Unallocated (calculated above) to be allocated to *prescribed entry and prescribed exit services*.

Infrastructure Cost allocated to Exit = \$1.5m

Item	Number	Allocation	Unallocated
Substation infrastructure costs		9,000,000	9,000,000
Total Breakers	6		
TUOS Stand-alone breakers	2		
Share to TUOS	0.333	3,000,000	6,000,000
Common Service stand-alone breakers	3		
Share to Common Service	0.500	4,500,000	1,500,000
Share to Entry and Exit services		1,500,000	

Example B

Substation Configuration

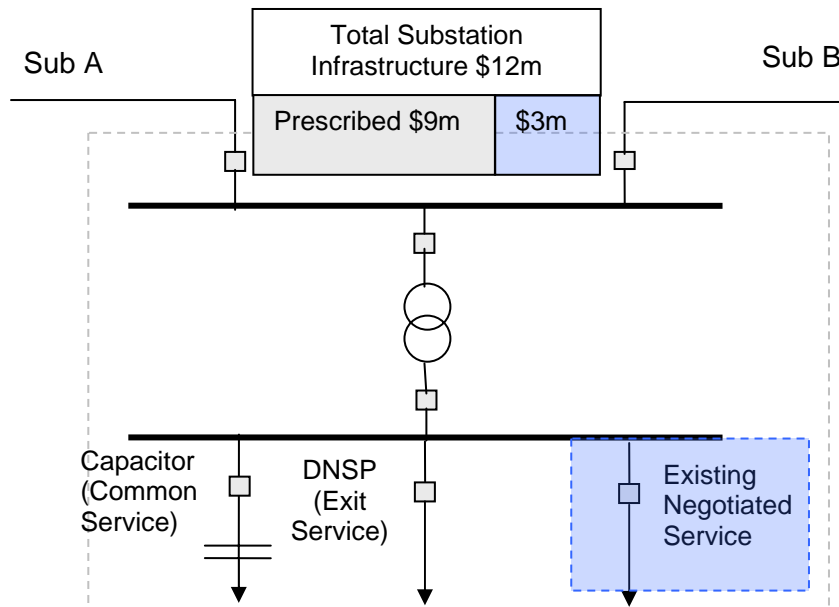

Step 1: The branches are Sub A, Sub B, DNSP, Tie Transformer, PCS and an existing negotiated service.

Step 2: The total number of circuit breakers directly connected to branches is 6 (no prescribed costs are allocated to the existing negotiated service).

Step 3.1: The stand-alone arrangement for the provision of *prescribed TUOS services* to an equivalent standard is shown below and consists of 2 circuit breakers.

Stand Alone Prescribed TUOS Service

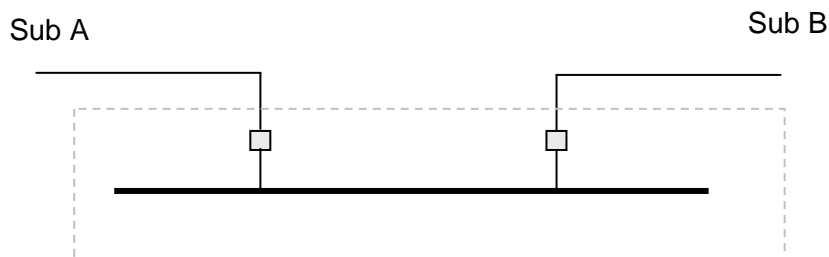

Step 3.2: The stand-alone arrangement for the provision of *prescribed common transmission services* to an equivalent standard is shown below and consists of 3 circuit breakers.

Stand Alone Prescribed Common Service

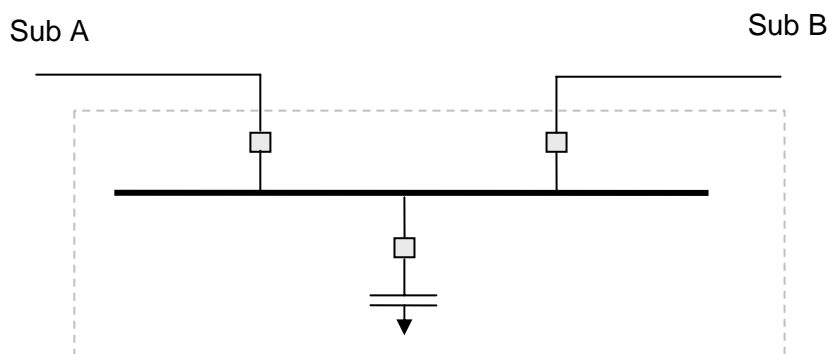

ElectraNet Revised Proposed Pricing Methodology – 3 April 2008

Step 4:

Assume total Infrastructure cost is \$12m, however \$3m is for the existing negotiated service, which does not form part of the regulated asset base and is not governed by 6A.23.2(d).

Costs are allocated to prescribed TUOS in the ratio of the circuit breakers in the stand-alone arrangement to the total circuit breakers.

Infrastructure Cost Allocated to TUOS = $(2/6) \times \$9m = \$3m$

Unallocated = $\$9m - \$3m = \$6m$

Costs are allocated to *prescribed common service* in the ratio of the circuit breakers in the stand-alone arrangement to the total circuit breakers.

Infrastructure Cost allocated to Common Service = $(3/6) \times \$9m = \$4.5m$

Unallocated = $\$6m - \$4.5m = \$1.5m$

Remainder of Unallocated (calculated above) to be allocated to *prescribed entry and prescribed exit services*.

Infrastructure Cost allocated to Exit = $\$1.5m$

Item	Number	Allocation	Unallocated
Substation infrastructure costs		9,000,000	9,000,000
Total Breakers	6		
TUOS Stand-alone breakers	2		
Share to TUOS	0.333	3,000,000	6,000,000
Common Service stand-alone breakers	3		
Share to Common Service	0.500	4,500,000	1,500,000
Share to Entry and Exit services		1,500,000	

Example C

Substation Configuration

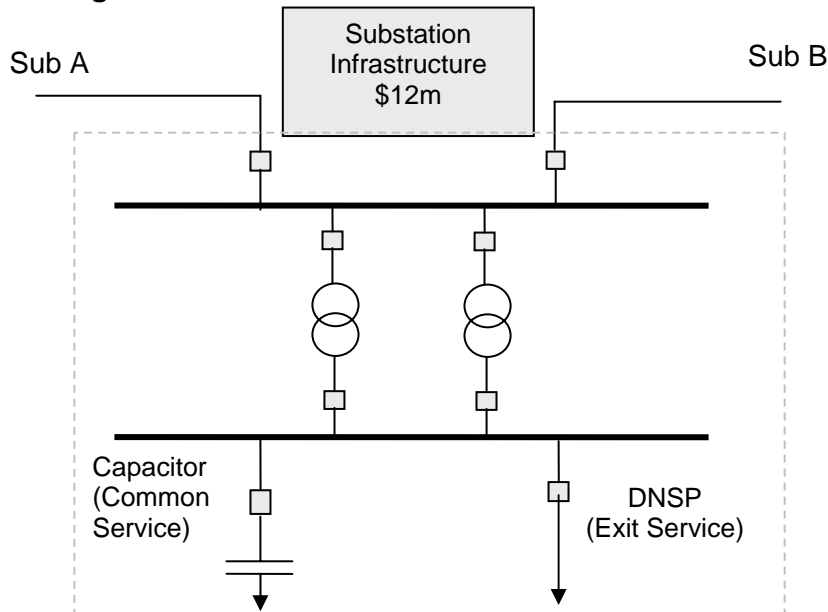

Step 1: The branches are Sub A, Sub B, DNSP, Tie Transformer 1, Tie Transformer 2 and PCS.

Step 2: The total number of circuit breakers directly connected to branches is 8.

Step 3.1: The stand-alone arrangement for the provision of *prescribed TUOS services* to an equivalent standard is shown below and consists of 2 circuit breakers.

Stand Alone Prescribed TUOS

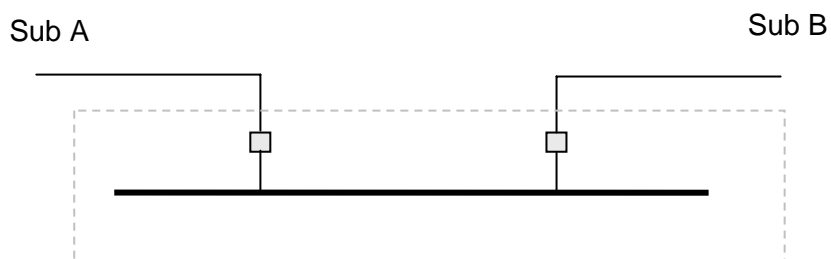

Step 3.2: The stand-alone arrangement for the provision of *prescribed common transmission services* to an equivalent standard is shown below and consists of 3 circuit breakers.

Stand Alone Prescribed Common Service

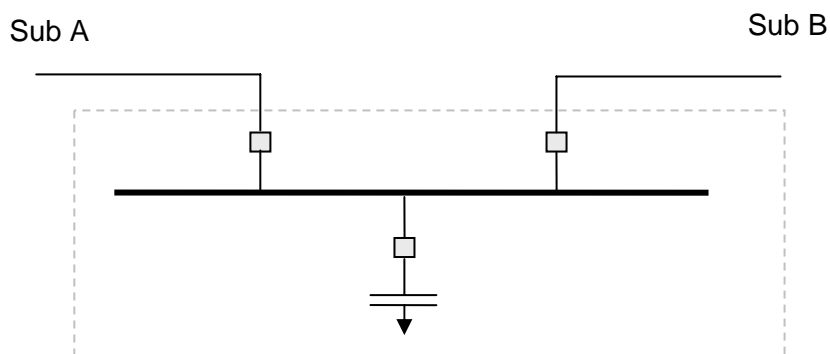

ElectraNet Revised Proposed Pricing Methodology – 3 April 2008

Step 4:

Assume total Infrastructure cost is \$12m.

Costs are allocated to prescribed TUOS in the ratio of the circuit breakers in the stand-alone arrangement to the total circuit breakers.

Infrastructure Cost Allocated to TUOS = $(2/8) \times \$12\text{m} = \3m

Unallocated = $\$12\text{m} - \$3\text{m} = \$9\text{m}$

Costs are allocated to *prescribed common service* in the ratio of the circuit breakers in the stand-alone arrangement to the total circuit breakers.

Infrastructure Cost allocated to Common Service = $(3/8) \times \$12\text{m} = \4.5m

Unallocated = $\$9\text{m} - \$4.5\text{m} = \$4.5\text{m}$

Remainder of Unallocated (calculated above) to be allocated to *prescribed entry and prescribed exit services*.

Infrastructure Cost allocated to Exit = $\$4.5\text{m}$

Item	Number	Allocation	Unallocated
Substation infrastructure costs		12,000,000	12,000,000
Total Breakers	8		
TUOS Stand-alone breakers	2		
Share to TUOS	0.250	3,000,000	9,000,000
Common Service stand-alone breakers	3		
Share to Common Service	0.375	4,500,000	4,500,000
Exit service		4,500,000	

Example D

Substation Configuration

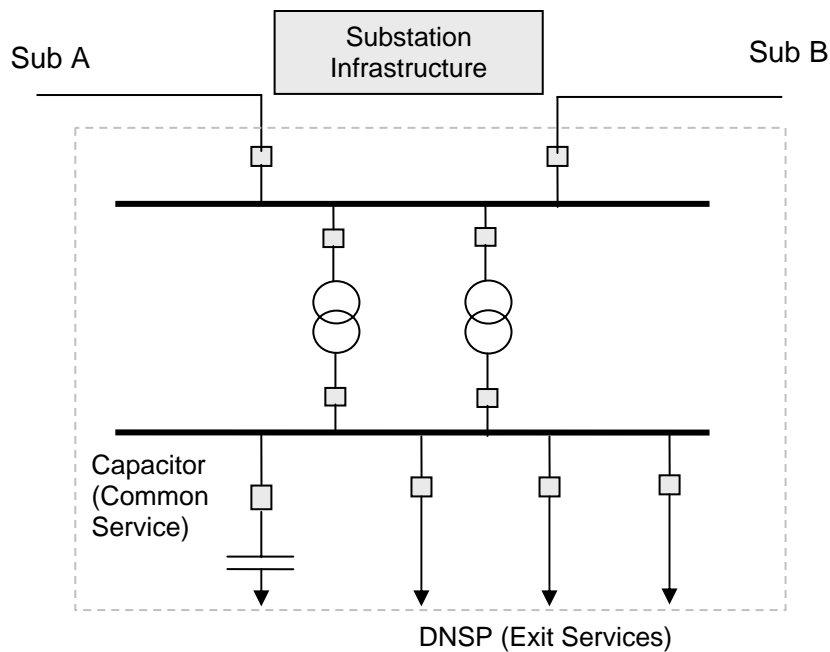

Step 1: The branches are Sub A, Sub B, DNSP1, DNSP2, DNSP3, Tie Transformer 1, Tie Transformer 2 and PCS.

Step 2: The total number of circuit breakers directly connected to branches is 10.

Step 3.1: The stand-alone arrangement for the provision of *prescribed TUOS services* to an equivalent standard is shown below and consists of 2 circuit breakers.

Stand Alone Prescribed TUOS

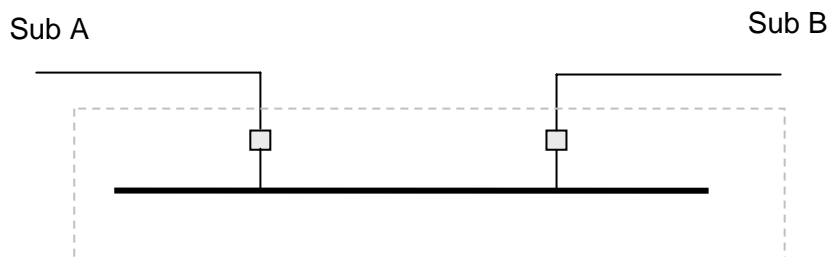

Step 3.2: The stand-alone arrangement for the provision of *prescribed common transmission services* to an equivalent standard is shown below and consists of 3 circuit breakers.

Stand Alone Prescribed Common Service

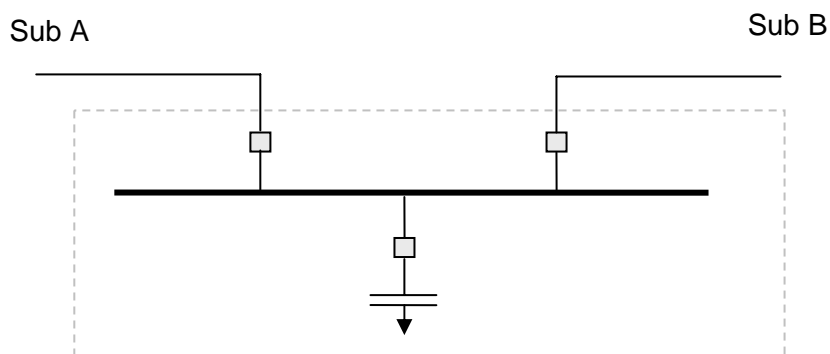

ElectraNet Revised Proposed Pricing Methodology – 3 April 2008

Step 4:

Assume total Infrastructure cost is \$15m.

Costs are allocated to prescribed TUOS in the ratio of the circuit breakers in the stand-alone arrangement to the total circuit breakers.

Infrastructure Cost Allocated to TUOS = $(2/10) \times \$15m = \$3m$

Unallocated = $\$15m - \$3m = \$12m$

Costs are allocated to *prescribed common service* in the ratio of the circuit breakers in the stand-alone arrangement to the total circuit breakers.

Infrastructure Cost allocated to Common Service = $(3/10) \times \$15m = \$4.5m$

Unallocated = $\$12m - \$4.5m = \$7.5m$

Remainder of Unallocated (calculated above) to be allocated to *prescribed entry and prescribed exit services*.

Infrastructure Cost allocated to Exit = $\$7.5m$

Item	Number	Allocation	Unallocated
Substation infrastructure costs		15,000,000	15,000,000
Total Breakers	10		
TUOS Stand-alone breakers	2		
Share to TUOS	0.200	3,000,000	12,000,000
Common Service stand-alone breakers	3		
Share to Common Service	0.300	4,500,000	7,500,000
Exit service		7,500,000	